

TIMKEN

PRODUCTS + SERVICES GUIDE

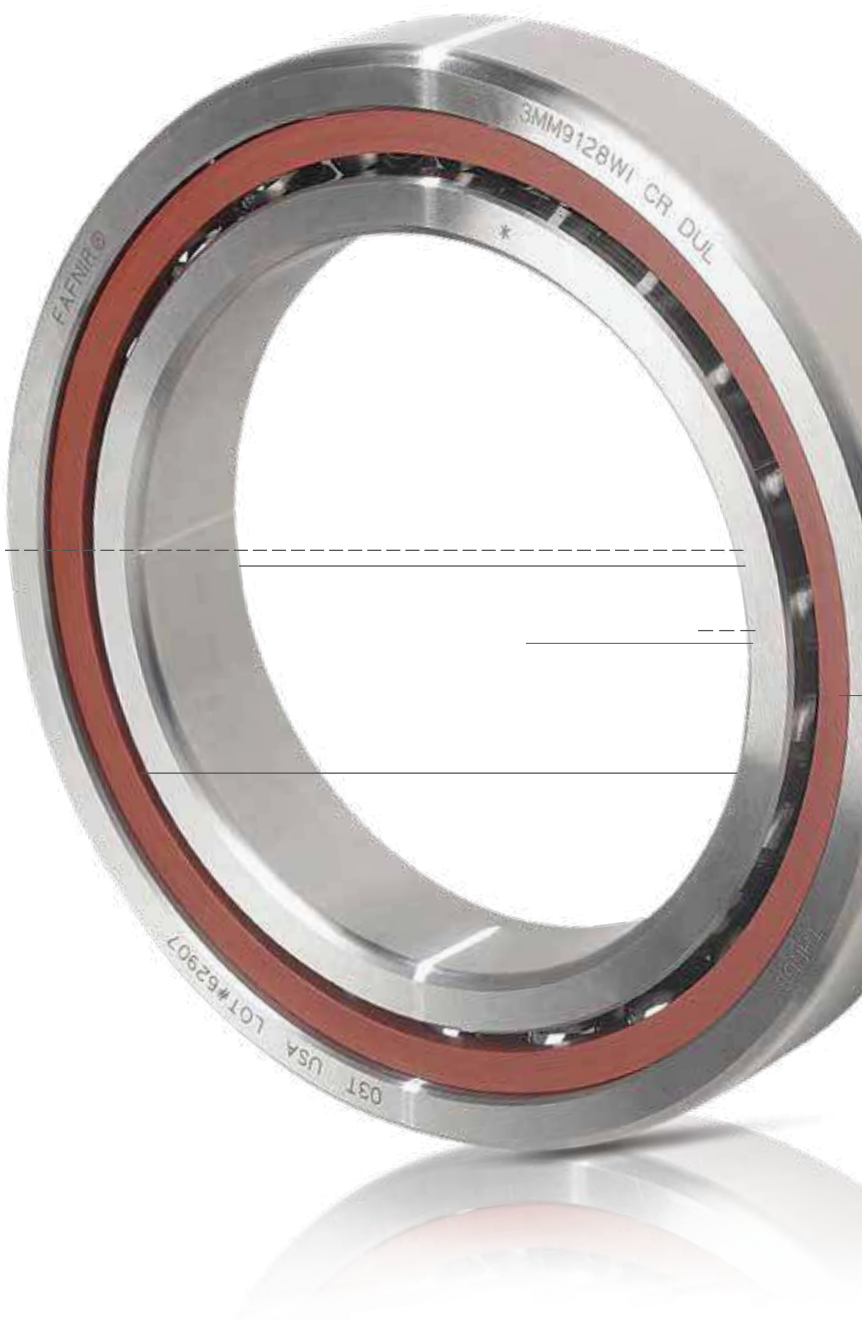











Let's work together to overcome your challenges. We are committed to your success. For more information, visit us at www.timken.com.







FRICION HAS MET ITS MATCH.

Designed for performance in a competitive world, our full range of engineered bearings, mechanical power transmission products and industrial services help equipment run better and boost your profitability.

ENGINEERED BEARING PRODUCTS

Timken® engineered bearings feature precision tolerances, proprietary internal geometries and quality materials. Our tapered, spherical, cylindrical, thrust, ball, plain, miniature, precision and housed unit bearings deliver strong consistent and reliable performance.





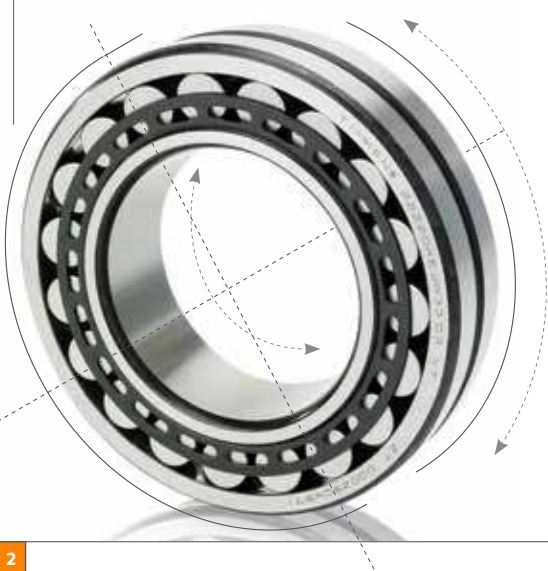



PRODUCT	SUMMARY	ADVANTAGES
BALL BEARINGS 	Engineered to perform in a wide range of applications, from electric motors to agricultural implements to food processing equipment	<ul style="list-style-type: none"> » Radial varieties tolerate relatively high-speed operation under various load conditions » Angular contact designs can support both radial and axial loads » The Timken® metric 6000 series is interchangeable with competitor products
MACHINE TOOL BALL BEARINGS 	Super precision tapered roller bearings, angular contact ball bearings and ball screw support bearings ideal for machine tool applications requiring tight tolerances	<ul style="list-style-type: none"> » Meet the highest industry standards in tolerance levels (including ABEC 9) » Sealed and ceramic balls are available for challenging application conditions
CYLINDRICAL ROLLER BEARINGS 	Comprehensive line of single-, double- and multi-row versions helps extend equipment life and lower maintenance costs	<ul style="list-style-type: none"> » EMA high-performance series offers premium brass land-riding cages that reduce operating temperatures
THRUST BEARINGS 	Ideal for when axial loads meet high speeds, heavy loads or other challenging conditions	<ul style="list-style-type: none"> » Get optimum performance with either standard or custom designs
PRECISION MINIATURE AND THIN SECTION BEARINGS 	Meet demanding application requirements for miniature and thin section bearings with a wide range of bearing types and design configurations	<ul style="list-style-type: none"> » ABEC 5 and ABEC 7 precision levels are standard » Application experts help select the right features for challenging environments » Wide range of styles and configurations including shields and seals
SPHERICAL PLAIN BEARINGS 	Support high-capacity radial and axial loads, ideal for static oscillatory applications where moderate misalignment may occur	<ul style="list-style-type: none"> » Hardened steel helps deliver consistent, reliable performance » Reduce installation time with simplified housing and shaft designs
SPHERICAL ROLLER BEARINGS 	Manage high radial loads with innovations that help extend bearing life and boost reliability	<ul style="list-style-type: none"> » Run at consistently lower temperatures than same-size competitive bearings
TAPERED ROLLER BEARINGS 	Timken® tapered roller bearing components are precisely designed to manage both axial and radial loads	<ul style="list-style-type: none"> » Increase power density with a smaller, lighter bearing

PRODUCT	SUMMARY	ADVANTAGES
INTEGRATED BEARING ASSEMBLIES 	Self-contained, pre-assembled bearing solutions for a variety of industries	» Solutions for automotive, heavy truck, racing, mining, and oil and gas
AP-2™ BEARING 	A shorter rail journal reduces axle flexure, creating less fretting wear between bearing components	» Reduce bearing set outs, fuel costs and bearing failures due to water ingress
ADAPT™ BEARINGS 	Combining cylindrical and spherical roller bearing designs into one easy-to-assemble, high-capacity configuration	» Ideal for applications with combined misalignment and axial displacement
PRECISION CROSSED ROLLER BEARINGS 	Combine the compact design of a single-row bearing with the stability of a two-row bearing and benefit from high rotational accuracy and rigidity in a space-saving manner	» Ideal as a table bearing for machine tools, including vertical boring and grinding machines
PRECISION AEROSPACE BALL BEARINGS 	Precision aerospace ball bearings, cylindrical and tapered roller bearings for a wide variety of aerospace applications including engines, gearboxes and landing wheels	» Timken® aerospace bearings are designed and manufactured to meet the performance requirements of critical flight systems
MULTIPLE-ROW BEARINGS 	Ideal for applications where moderate and high speeds, high-radial loads, elevated temperatures and extreme debris present constant challenges	» Four-row tapered roller bearings for radial and axial loading » Four-row cylindrical roller bearings for radial loading applications
COATINGS AND ENGINEERED SURFACES 	Hard coatings and topographical modifications help boost the performance of precision components in difficult applications	» Enhance performance and reliability in equipment with marginal lubrication or in high-debris environments











HOUSED UNITS (MOUNTED BEARINGS)

Stronger outside, smarter inside. Timken® housed units or mounted bearings deliver a single brand solution for consistency, control and confidence.

PRODUCT	SUMMARY	ADVANTAGES
BALL BEARING HOUSED UNITS 	Easy installation, multi-seal design and flexible options support a wide range of demanding applications and conditions	<ul style="list-style-type: none"> » Provide advanced protection against contaminants in a robust, compact unit » Fafnir® robust block outperforms standard housed units in the most challenging applications and environments
U SERIES HOUSED UNITS 	A wide range of ready-to-mount units with seal flinger design deliver protection against contamination in demanding applications.	<ul style="list-style-type: none"> » Two piece sealing with contact lip seal and flinger for additional protection
TYPE E TAPERED ROLLER BEARING HOUSED UNITS 	Features the highest dynamic load ratings in the industry	<ul style="list-style-type: none"> » Triple-barrier seal for industry leading protection against contamination » Secondary sealing system with open and closed end covers are available for additional robust protection
SPHERICAL ROLLER BEARING SOLID-BLOCK HOUSED UNITS 	Cast-steel housings with high-performance spherical roller bearings for outstanding durability in extreme conditions, including severe shock loads and vibration	<ul style="list-style-type: none"> » Easy to mount and align in 15 minutes » Keep contamination out with multiple sealing options
SNT/SAF PLUMMER (PILLOW) BLOCK HOUSED UNITS 	Customizable design, interchangeable components and reliable spherical roller bearings provide heavy-duty performance	<ul style="list-style-type: none"> » Easily convert from fixed to float configurations in the field » Split housing allows for removal of cap for easy assembly and bearing inspection
SPLIT CYLINDRICAL ROLLER BEARING HOUSED UNITS 	Ideal for trapped applications in high-service cost locations with a split-to-the-shaft design available in a variety of housing styles	<ul style="list-style-type: none"> » Reduce inspection and replacement time dramatically » Increase operational life and reduce maintenance expense
POLY-ROUND® SOLUTION® BEARINGS 	USDA-accepted bearings made from high-performance polymers – greaseless, non-corrosive designs promote food safety	<ul style="list-style-type: none"> » Eliminate lubrication time and expenses, reducing maintenance costs » Solution® housings feature maximum cleanability, with smooth surfaces and minimal crevices
SPECIALIZED MOUNTED BEARINGS 	Innovative, non-corrosive designs help elevate food safety and production uptime with improved reliability	<ul style="list-style-type: none"> » The only USDA-NSF accepted bearings available » Interchange mounted bearings from ½ in. to 5 in. and metric with EDT products » For temperatures from cryogenic to 1000° F

MECHANICAL POWER TRANSMISSION











Our growing mechanical power transmission product portfolio can improve the reliability and efficiency of industrial equipment and machinery. Carlisle® belts, Drives® chain, Lovejoy®, EDT® and Torsion Control System couplings, Philadelphia Gear® gearboxes, Groeneveld and Interlube™ lubrications systems and PT Tech® brakes and clutches provide customers a variety of solutions to keep industry in motion.

PRODUCT	SUMMARY	ADVANTAGES
AUGERS 	Helicoid and sectional augers available for industrial applications like conveyors, diggers and combines	<ul style="list-style-type: none"> » Helicoid augers reduce friction, wear and power requirements in screw conveyors moving bulk materials » Sectional augers fit heavy-duty requirements in applications needing a thicker outside diameter flight edge – providing extended wear life
BELTS 	Purpose-built and designed for optimal performance in a multitude of demanding applications	<ul style="list-style-type: none"> » Comprehensive line of premium-quality heavy-duty v-belts and synchronous belts » Engineered and built to rigid specifications to provide superior performance and reliability
PRECISION ROLLER CHAIN 	Manufactured to meet or exceed ANSI standards and excel in tough, high-performance applications	<ul style="list-style-type: none"> » Wide-waisted link plates help improve stress distribution for better performance » Large pitch roller chain link plates are ballized after heat treatment for increased fatigue strength » 50 percent pre-loading for minimum to no initial stretch after chain installation » Engineered Class chains are available
UNIVERSAL JOINTS 	Strong, durable and flexible, joints are designed to be disassembled and reassembled without damage to the component and can be readily taken apart without special tools	<ul style="list-style-type: none"> » Made of alloy steel, solid hubs can be modified to fit customer specifications » Built-in system provides sustained lubrication and no special tooling is needed to assemble or disassemble
MAINTENANCE TOOLS 	Install, remove and maintain bearings in the easiest, safest manner possible, including impact fitting tools, hydraulic/mechanical pullers and induction heaters	<ul style="list-style-type: none"> » Maximize productivity and uptime » Hands-on field training provides practical instruction on tool use and maintenance
COUPLINGS 	Easy to install and requiring no lubrication, their lifespan matches the rotating equipment to help lower overall cost of ownership	<ul style="list-style-type: none"> » Transmit the same or higher torque than a gear, grid, chain or other elastomeric coupling with similar dimensions » Insert is easy to replace without moving hubs – maintenance takes minutes » Sized to fit virtually all needs, with multiple hub and shaft combinations for easy mounting
JAW IN-SHEAR COUPLINGS 	The Jaw In-Shear coupling reduces downtime and maintenance	<ul style="list-style-type: none"> » Easy spider replacement » No tools needed » Use existing Lovejoy hubs » Replace spider in minutes without removing hubs » Twice the misalignment capacity over standard jaw coupling
MAINTENANCE-FREE COUPLINGS 	The revolutionary disc pack profile design can accommodate 1/2° to 1.5° of angular misalignment	<ul style="list-style-type: none"> » Eliminates the need for lubrication and coupling maintenance » Can be inspected without disassembly » Disc packs can be inspected with a strobe light while the machine is running » No wearing parts
LUBRICATED COUPLINGS 	Incorporating the latest advances in Finite Element Analysis (FEA) technology, Lovejoy has revolutionized the gear coupling	<ul style="list-style-type: none"> » Unequaled bore and torque capacity » 1.5° of misalignment per gear mesh » Enhanced fastener corrosion resistance » Advanced seal design, increases contamination resistance » Interchangeable with standard AGMA

PRODUCT	SUMMARY	ADVANTAGES
SPRING COUPLINGS 	Engineered spring couplings are tuned specifically for customers' most demanding applications to isolate torsional vibration from the system	<ul style="list-style-type: none"> » Quick response time for customer specific solutions » Precise tuning for best isolation » High heat resistance compared to elastomeric designs » Consistent stiffness over time and temperature
BRAKES 	A wide variety of brake sizes and styles in demanding industrial applications including underground coal mining, steel, and marine	<ul style="list-style-type: none"> » Highly engineered, rigorously tested designs for demanding applications » Unrivaled energy capacity provides long life and reliable performance » Endlessly rebuildable with easy-to-use kits
CLUTCHES 	Microprocessor controlled hydraulically applied clutch. Offered in both wet and dry configurations. Designed for industrial diesel engines ranging from 80 - 1600 HP	<ul style="list-style-type: none"> » Advanced control logic provides "Push Button" engagement preventing operator abuse » Monitors and reports system status » Self-adjusting for wear » Designed to absorb shockloads
TORQUE LIMITERS 	Continuously engaged friction torque limiters provide consistent, reliable, maintenance-free torque protection in a wide variety of demanding industrial applications	<ul style="list-style-type: none"> » Highly engineered, rigorously tested designs for demanding applications » Unrivaled energy capacity provides long life and reliable performance » Patented design provides consistent torque throughout the wear life with no need for adjustment » Endlessly rebuildable with easy-to-use kits
GEARBOXES/ TRANSMISSIONS 	Low- and high-speed gear drive designs are used in large-scale industrial applications; custom-made systems meet user specifications in a wide-array of size, footprint and gear arrangements	<ul style="list-style-type: none"> » Manufacture, precision assembly and testing of new gearboxes » Solutions from a single gear to complete transmissions
GREASE/LUBRICATION 	Application- and environment-specific selection of industrial, automotive and rail lubricants developed for optimum bearing performance	<ul style="list-style-type: none"> » Help extend bearing life, relubrication intervals and protect equipment » Keep operations running efficiently and reduce maintenance costs
LUBRICATORS 	Dispense precise amounts of lubricants in a wide range of applications and operating conditions, from simple, single-point needs to multi-point or progressive systems	<ul style="list-style-type: none"> » Single-point lubricators tailored to specific environments and requirements
INTERLUBE AUTOMATIC LUBRICATION SYSTEM 	Reliably distribute lubricant with automated systems offering solutions for commercial vehicles, construction, mining and heavy and general industries	<ul style="list-style-type: none"> » Increase plant and vehicle productivity and profitability » Reduce process downtime
AUTOMATIC LUBRICATION SYSTEMS 	For a wide range of automatic lubrication solutions, oil management or safety support systems, Groeneveld products deliver safety and efficiency at every work site	<ul style="list-style-type: none"> » Improved vehicle/machine uptime leads to higher productivity » Extended service life of critical components means lower repair and maintenance costs. Higher residual value » Improved safety for workers; decreased environmental burden
SEALS 	A variety of types and material options provide resistance to extreme temperatures, pressure, debris and most chemicals	<ul style="list-style-type: none"> » Contact and non-contact designs suit any application » Durable materials offer long seal life and minimize maintenance » Secondary seals, covers and end caps provide extra protection

INDUSTRIAL SERVICES

Timken offers bearing and power system rebuild and repair services that can return components or entire systems to like-new. We overhaul drive train products, including switchgears, control panels, electric motors, generators, gear drives, bearings and couplings. We also repair uptower wind turbines and cranes.

PRODUCT	SUMMARY	ADVANTAGES
GEARBOXES AND ELECTRIC MOTOR REPAIR 	Inspect, repair and upgrade gearboxes, electric motors and controls to OEM specs – regardless of manufacturer	<ul style="list-style-type: none"> » Expansive knowledge base and problem-solving skills to meet any challenge
BEARING REMANUFACTURING 	Returns any brand of bearing used in heavy industrial, rail and aerospace applications to like-new condition	<ul style="list-style-type: none"> » Extend service life by up to three times » Save up to 60 percent on the cost of replacement bearings
CRANE REPAIR 	Field services for upgrades, service, inspection, load testing and repair for all brands of cranes	<ul style="list-style-type: none"> » Modernizations and updates » Services » Spare parts for cranes and hoists
TRANSMISSIONS REPAIR 	Remanufacture and repair of aerospace systems and rotorcraft transmissions	<ul style="list-style-type: none"> » Expertise in design, specification and maintenance
UPTOWER WIND TURBINE MAINTENANCE AND REPAIR 	On-site service by trained technicians for drive train maintenance and uptower repair of wind turbines	<ul style="list-style-type: none"> » Gearbox maintenance and oil changes » Generator reconditioning/rewinds » Uptower generator bearing, slip ring, brush rigging and change-outs
TECHNICAL CAPABILITIES 	Benefit from cleaner, stronger materials and an ever-growing selection of high-performance product from an expert with more than a century of experience in friction management and materials science	<ul style="list-style-type: none"> » Application engineers identify and overcome unique challenges, using the most advanced analytics in the industry
ADVANCED BEARING ANALYSIS SYSTEM 	Syber analyzes bearing systems, helps optimize design and development, and predicts potential damage	<ul style="list-style-type: none"> » Speed system concept-to-design stage with fewer test requirements » Customer-specific software versions offer base design analytic capabilities
ONLINE SERVICES 	Enjoy the ease and convenience of online services with a variety of options	<ul style="list-style-type: none"> » Find product selection tools, CAD drawings, dimensional tolerances and more at cad.timken.com » Check product availability, place orders and track order status – 24/7 at our online stores
TRAINING AND CERTIFICATION 	On-site training, end-user maintenance seminars and bearing certification programs help your team select bearings and optimize system performance	<ul style="list-style-type: none"> » Tailored training programs range from bearing basics to advanced best practices » Certification programs help maintenance shops improve efficiency and performance
SERVICE ENGINEERING 	On-site engineers help solve challenges and prevent future problems using data, testing and technical resources	<ul style="list-style-type: none"> » Get on-site problem solving, life cycle calculations, interface design options, bearing inspections and evaluations » Find new ways to improve efficiency and productivity

Innovation makes the world stronger and more efficient. Our world-class engineers and technologists use advanced science to minimize the friction that limits productivity.

We create value designed with the customer in mind. Focus, precision and passion for details deliver measurable and enduring results.

Work with Timken to overcome your toughest challenges.

Together, we are **stronger, by design.**

For more information, visit us at www.timken.com.



TIMKEN

- » ENGINEERED BEARING PRODUCTS
 - BEARINGS
 - HOUSED UNITS
- » MECHANICAL POWER TRANSMISSION
- » INDUSTRIAL SERVICES

WWW.TIMKEN.COM

The Timken team applies their know-how to improve the reliability and performance of machinery in diverse markets worldwide. The company designs, makes and markets high-performance mechanical components, including bearings, belts, brakes, clutches, chain, couplings, gears and related mechanical power transmission products and services.

Stronger. By Design.

10M 01-18 :29 Order No. 10725
Timken® is a registered trademark of The Timken Company.
© 2018 The Timken Company | Printed in U.S.A.