

Products



1979

1995

2001

2007

2011

2017

2019

2024

SONY



Manufacturing & 3PL

Tape & Optical Media Technology

EMS

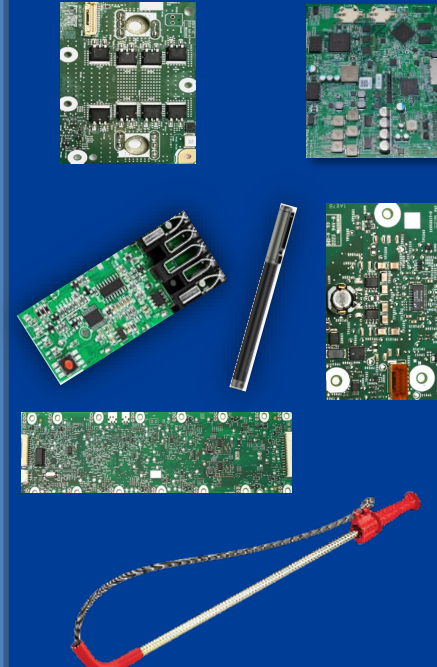

- Power Tools
- Automotive
- Household Tool

- Energy
- Gaming
- Education



Repair & Recertification



- CE
- Medical



TKR VIDEO

<https://tkrdemexico.com/2020/10/30/tkr-de-mexico-s-a-de-c-v-introductory-video/>

"All services and products that we deliver start from **listening to the customer's voice.**"

Satoshi Ota President and CEO

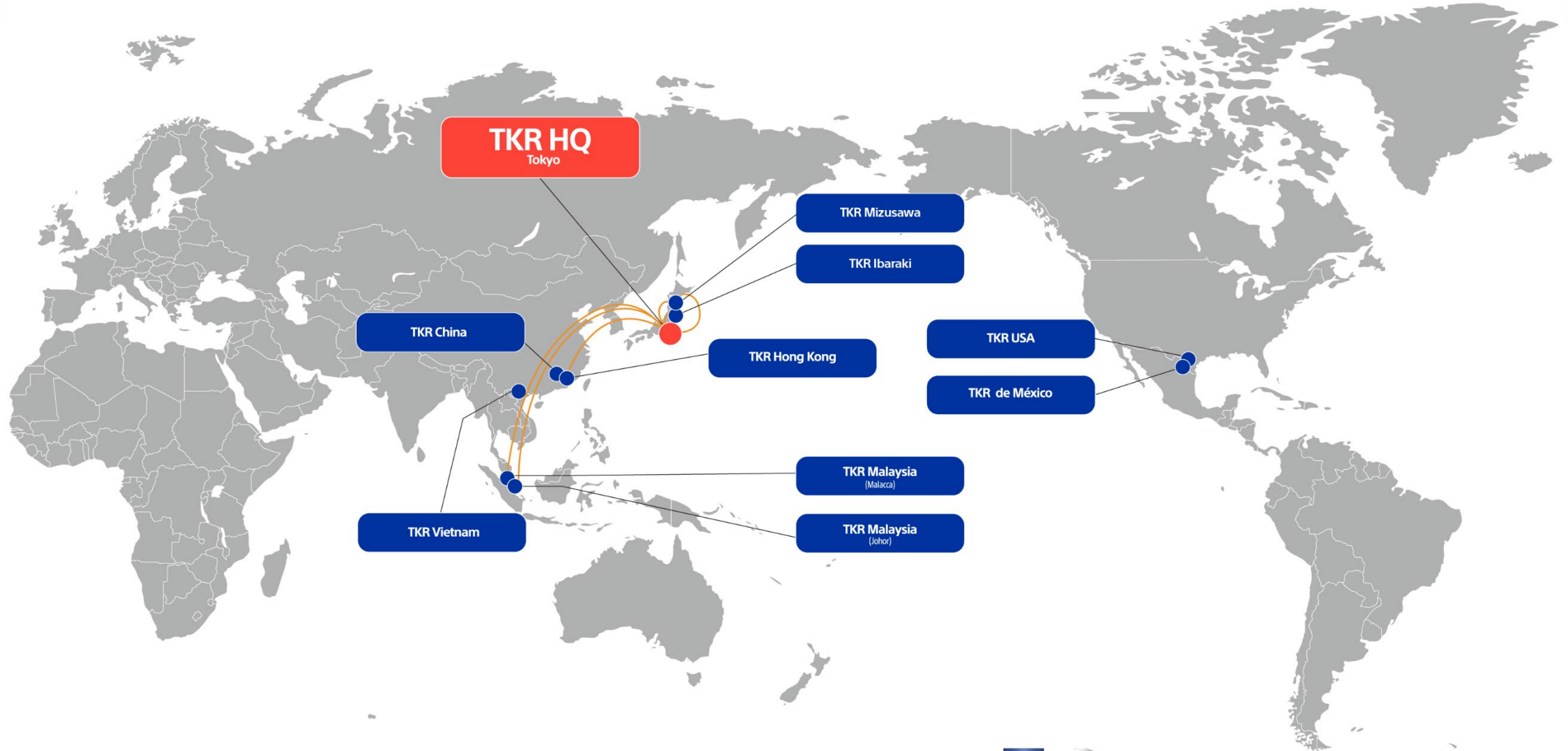

Distribution Center

TKR USA Inc.

Located in Laredo, Texas

- Receiving
- Warehousing
- Customer Service

Factory

TKR de México S.A. de C.V.

Located in Nuevo Laredo, Tamaulipas

- Manufacturing
- Repair/Refurbish/Exchange

Overview

- **Established:** November 1979 as Sony
- **Acquired by TKR Corporation:** April 1st, 2019
- **Main Operation:**
 - Electronic Manufacturing Services
 - Final Assembly
 - Reverse Logistics

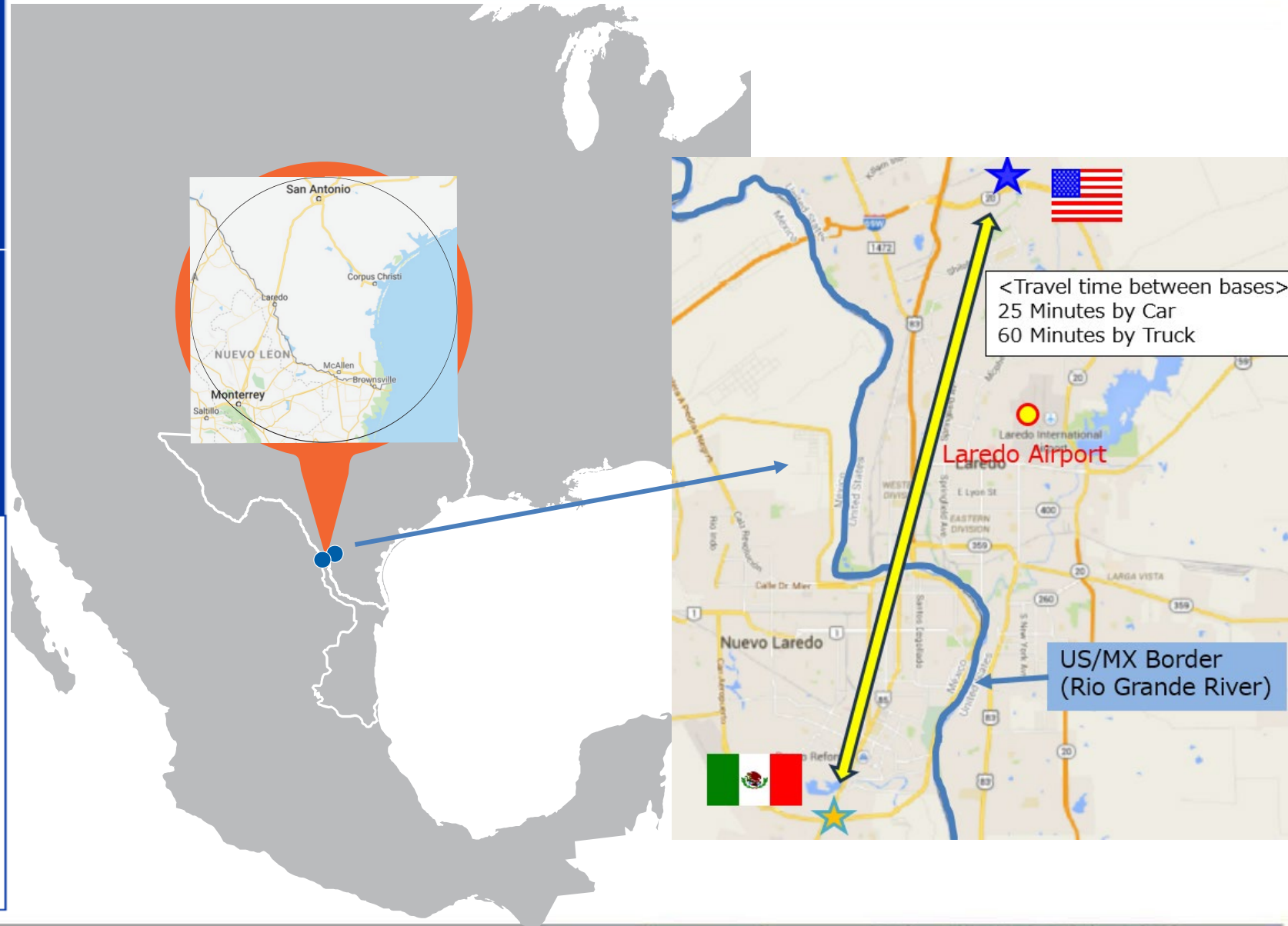

EMS
Engineering
Continuous Improvement

EMS SOLUTIONS

MANUFACTURING SERVICES

SOFTWARE DEVELOPMENT & JIG DESIGN

SYSTEM INTEGRATION & TEST

QUALITY & PRODUCT ASSURANCE

Equipment and advantage

- Clean Room Class ISO7
- Temperature, Humidity and ESD management
- 3D solder inspection
- 3D mount inspection
- Nitrogen (N2) reflow
- ICT (Integrated Circuit Test)
- Robot Solder Station (Hakko)



N
NITROGEN



SMT (Process Flow)



Panasonic

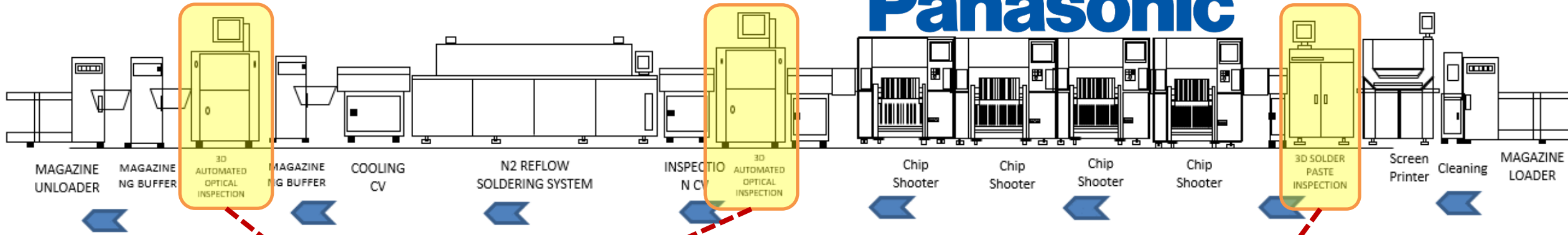

AOI Pre & Poss. (Kohyoung)

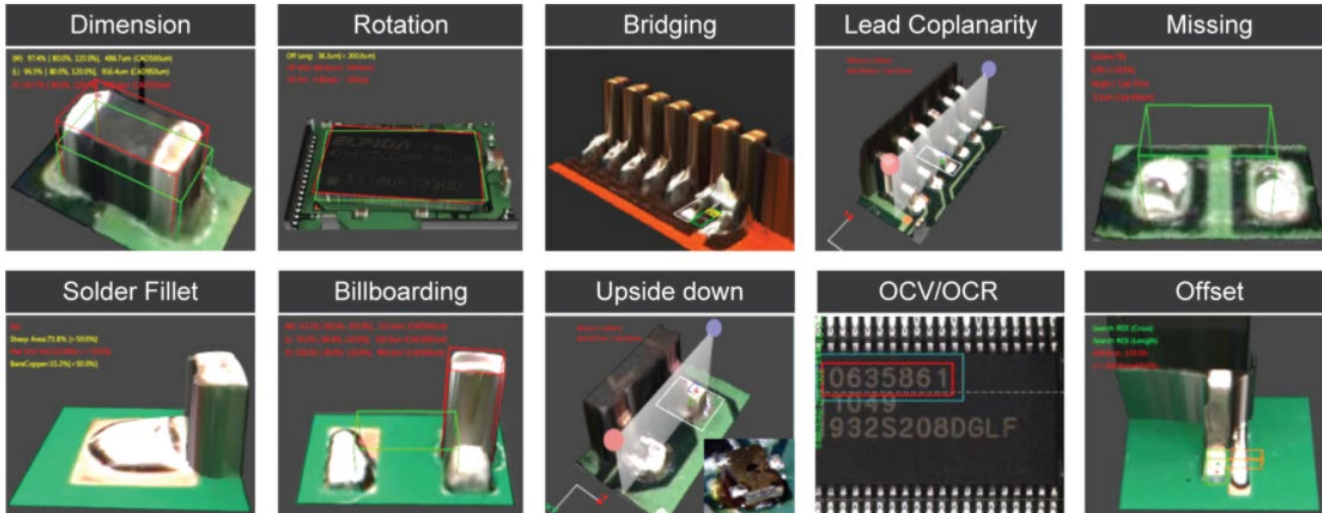

SPI (Kohyoung)

Koh Young - SPC Capability

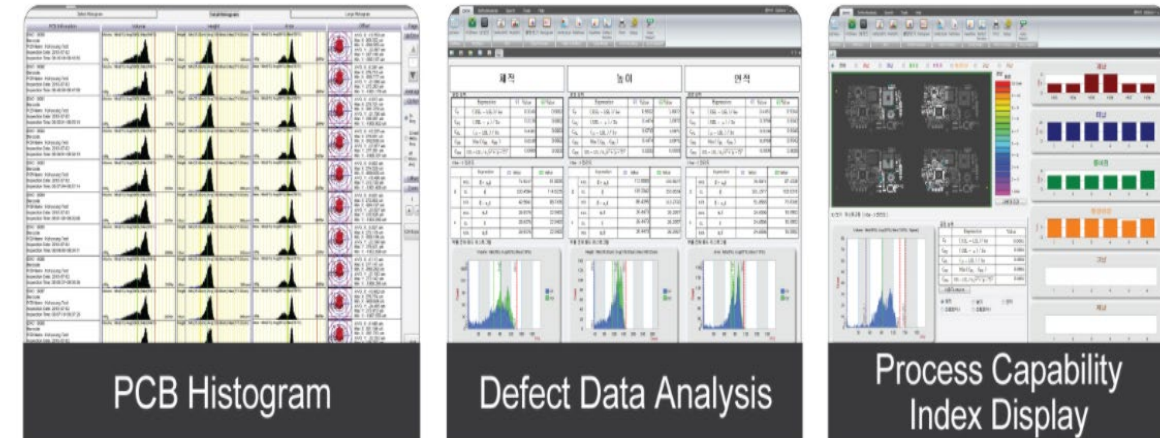

Traceability Concept

1 Parts Traceability

Part Number, Mfg. Number,
Lot Number, Part Supply
Time and Quantity

2 Production History & Control

Production Record, OK/NG
Record, Rework Record,
Shipment History

3 Process Control

Avoid Process Skip until
packaging. Avoid input
different Model in Line.

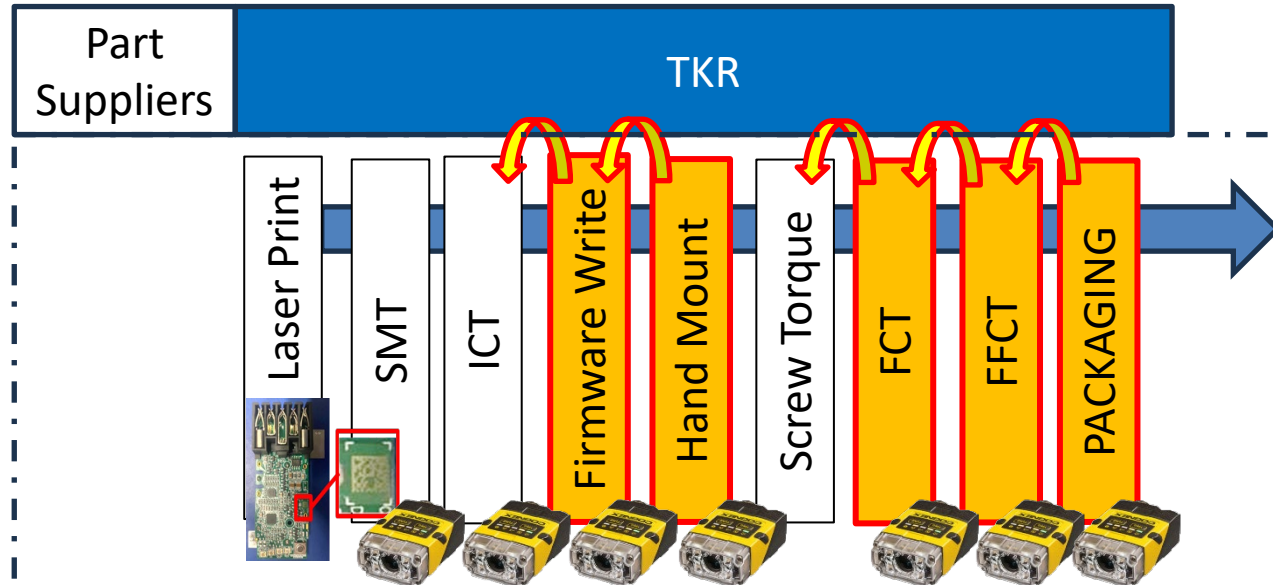

(1) Skip Process

- Ensure all products pass all process.
- Ensure all shipped products are OK functionally.
- Prevent model mixing.

(2) Real Time Data Analysis

Repair & Refurbish Operation

Repair SONY Medical - Primary Customer Base



STORZ
KARL STORZ — ENDOSKOPE

Arthrex®

stryker®
Endoscopy



GE Healthcare

PHILIPS
Healthcare

**Boston
Scientific**

 **CONMED**™
L I N V A T E C

OLYMPUS®



Capabilities

Tailored service capabilities to meet and exceed customer requirements while maintaining the lowest costs possible.



Board
Component
level repair



Cosmetic and
mechanical
repair



Salvage parts,
recovery
& testing



Electrical
troubleshooting
and module
replacement



Software
update
services

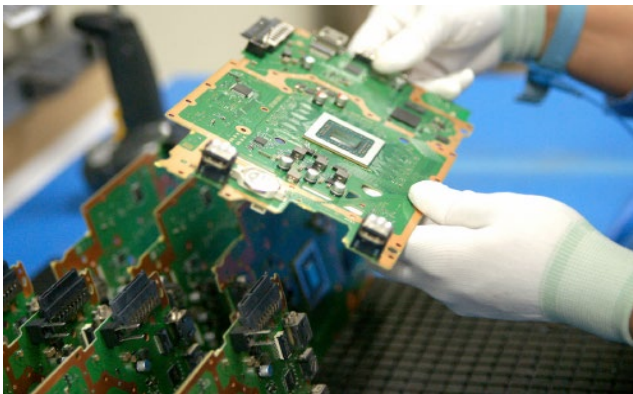

Turn
Around
Time
1.6
days



Supply Chain Management

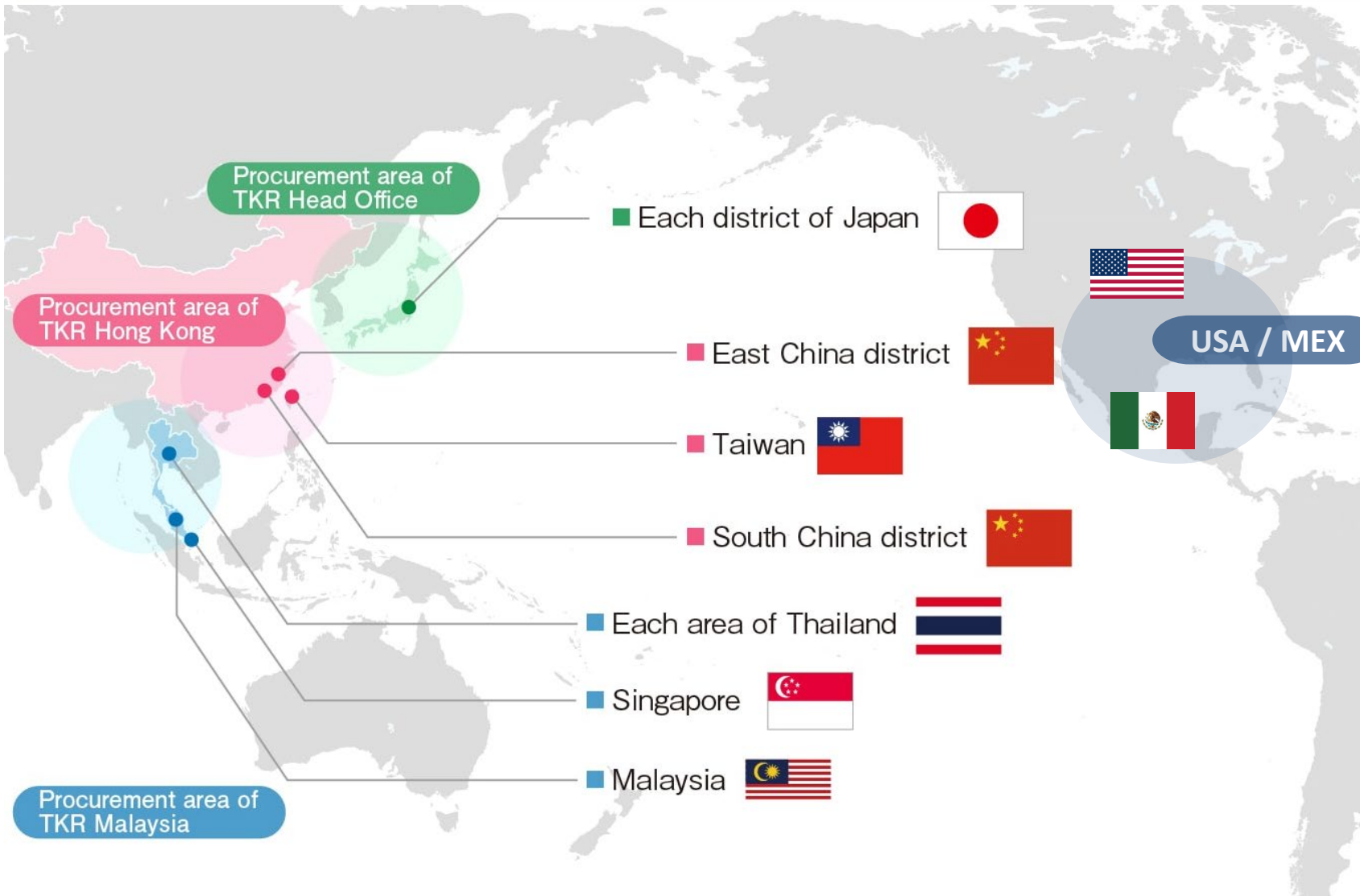

- **Local and Global Sourcing**
- **TKR HQ as IPO Negotiating Parts on a Global Scale**
- **VMI Program**
- **Market and Risk Monitoring**
- **Value Analysis (VA).**
Evaluate existing parts for cost-saving opportunities.

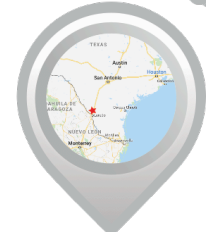
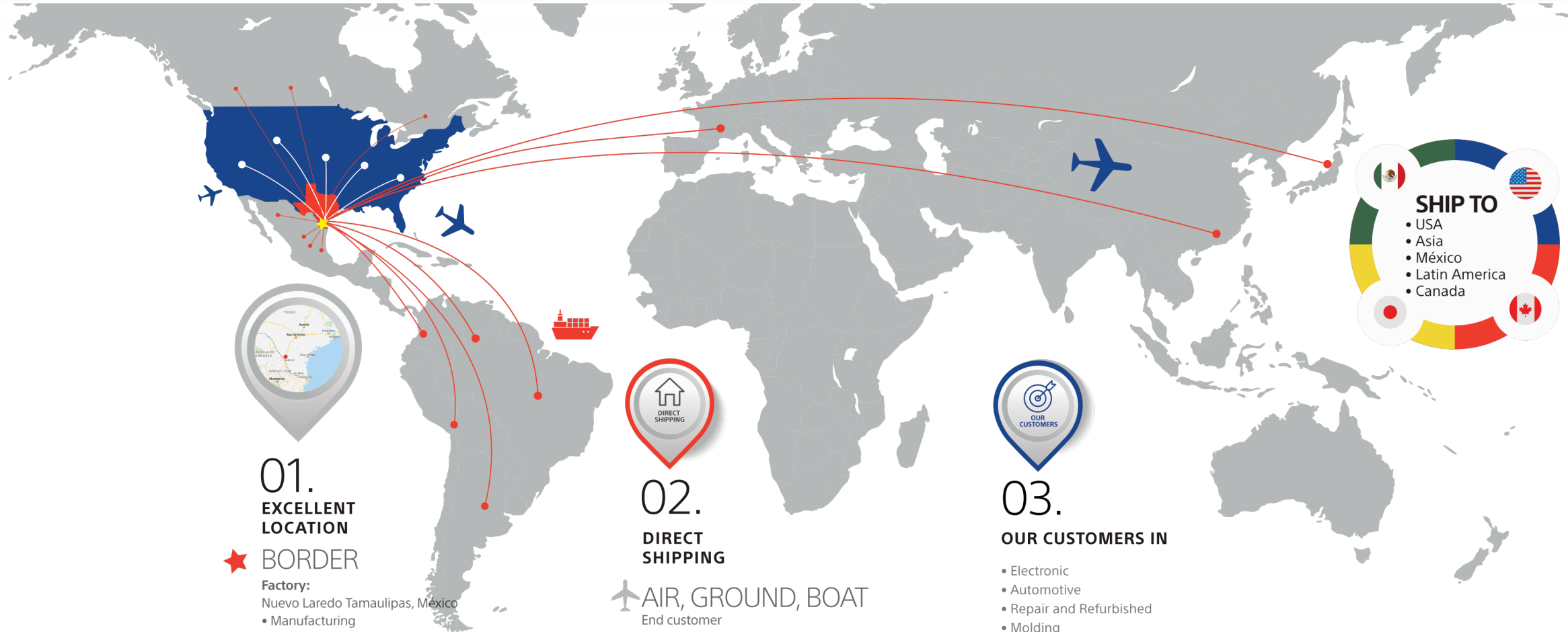

01. EXCELLENT LOCATION

★ BORDER

- Factory:**
 Nuevo Laredo Tamaulipas, México
 • Manufacturing
- Distribution Center:**
 Laredo Texas, USA
 • Logistics
 • Customer Service



02.

DIRECT SHIPPING

✈️ AIR, GROUND, BOAT

End customer direct shipping

⚙️ VIA
 FedEx, UPS, DHL and others



03.

OUR CUSTOMERS IN

- Electronic
- Automotive
- Repair and Refurbished
- Molding

SHIP TO

- USA
- Asia
- México
- Latin America
- Canada





Government Certifications



IMMEX

- ✓ Manufacturing, Maquiladora, & Export Services Industry



- ✓ It is the CTPAP for MX
- ✓ Our Plant was among the first ones to get certification

Opinion Positiva

- ✓ Demonstrate Business is reliable and in compliance with Tax laws
- ✓ It is required for IVA/IEPS & PROSEC Certification

IVA|IEPS

- ✓ Certification allows deferral of tax payments through a government-issued credit note, improving cash flow.

PROSEC

- ✓ Sectoral Promotion Programs certification allows companies in some industries to import some goods at reduced or zero tariffs

- ✓ One of the initial Participants in 2001
- ✓ The FIRST ever CTPAP shipment to USA was from this Plant.

- ✓ TKR Distribution Center in USA is FTZ certified
- ✓ Merchandise is not subject to U.S. duty or excise tax.
- ✓ Personal Property Taxes are exempt from State and Local



Foreign Trade Zone

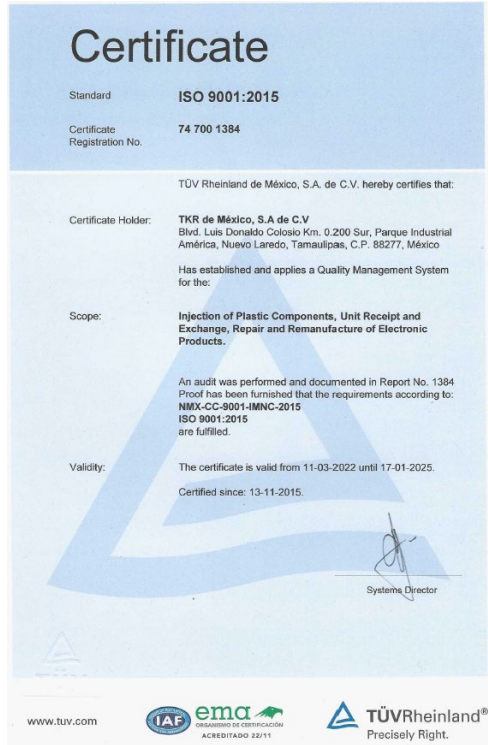

ISO 9001:2015



ISO 14001:2015

SONY

2021/5/06

グリーンパートナー環境品質認定通知書
 Notification of Green Partner Certification

Attn : TKR USA Inc.

評定 貴社益々ご清業のこととお慶び申し上げます。
 平素は、弊社環境品質保証活動に多大なるご協力を賜り、お礼申し上げます。
 貴社のグリーンパートナー環境品質認定手続きが完了しましたのでご通知申し上げます。
 今後とも弊社環境品質保証活動にご協力を賜りますようお願い致します。
 Thank you for your kind support on Sony Green Partner Activities.
 We would like to inform you that Green Partner Certification has been authorized.
 Your continuous cooperation on Sony environmental quality assurance activities is highly appreciated.

認定範囲 / Scope of Green Partner Certification

ファクトリーコード	マニファクチャラー名称 (英文)	工場名称 (英文)	監定期限
Factory Code	MC Name	PC Name	Expiry Date
FC014916	Factory Code.: FC014916	TKR de México, S.A. de C.V.	2024/7/31

ソニー株式会社 / Sony Corporation
 調達センター / Procurement Center
 グリーンパートナー事務局 / Green Partner Secretariat



In Process

Sony Green Partner

Recognitions

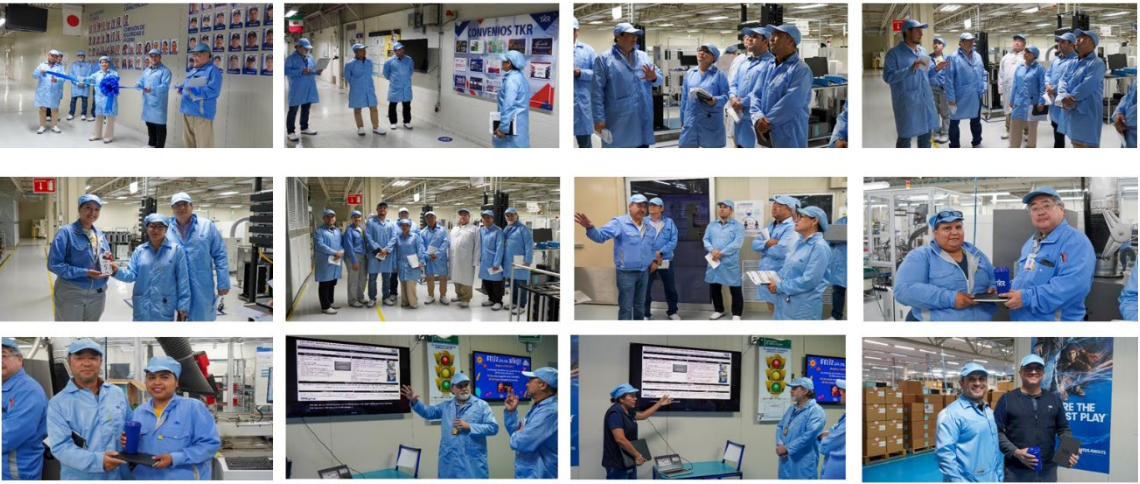

Seniority and Perfect attendance

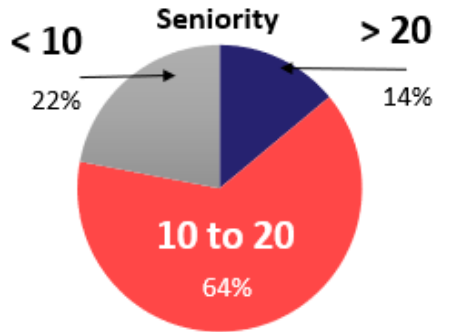

Mothers & Fathers Day

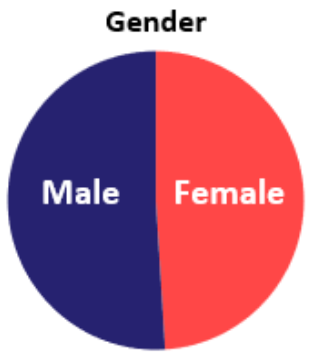

School Supplies and Children Day

