

Ceat

Ceat Design and Manufacturing Systems S. de R.L. de C.V.



Company Background

- Tecnica Test was founded in 1985 and in 2006 Ceat was opened to cover the necessities of our customers as a design engineering center, moving to the manufacturing area starting in 2008 doing the first integrations with a manufacturing size of 2152 sqft.
- Yearly manufacturing capacity:
 - 10 Inspections cells with automation.
 - 42 jigs fixtures.
 - Special machining parts and design.
- Max value project automatic inspection of cracks and internal defects, 600k.
- Our biggest size work has been 125 X 31 ft. for GKN



Mission, Vision and values

- Mission:
 - Create security by ensuring the quality through applied innovation and engineering.
- Vision (2025):
 - Being recognized as a high-tech company in the Mexican industry.
- Values:
 - Integrity: Be all you can be with strong ethical principles – Do the right thing.
 - Innovation: The only way to survive is to continuously transform into something else.
 - Productivity: Do more with less

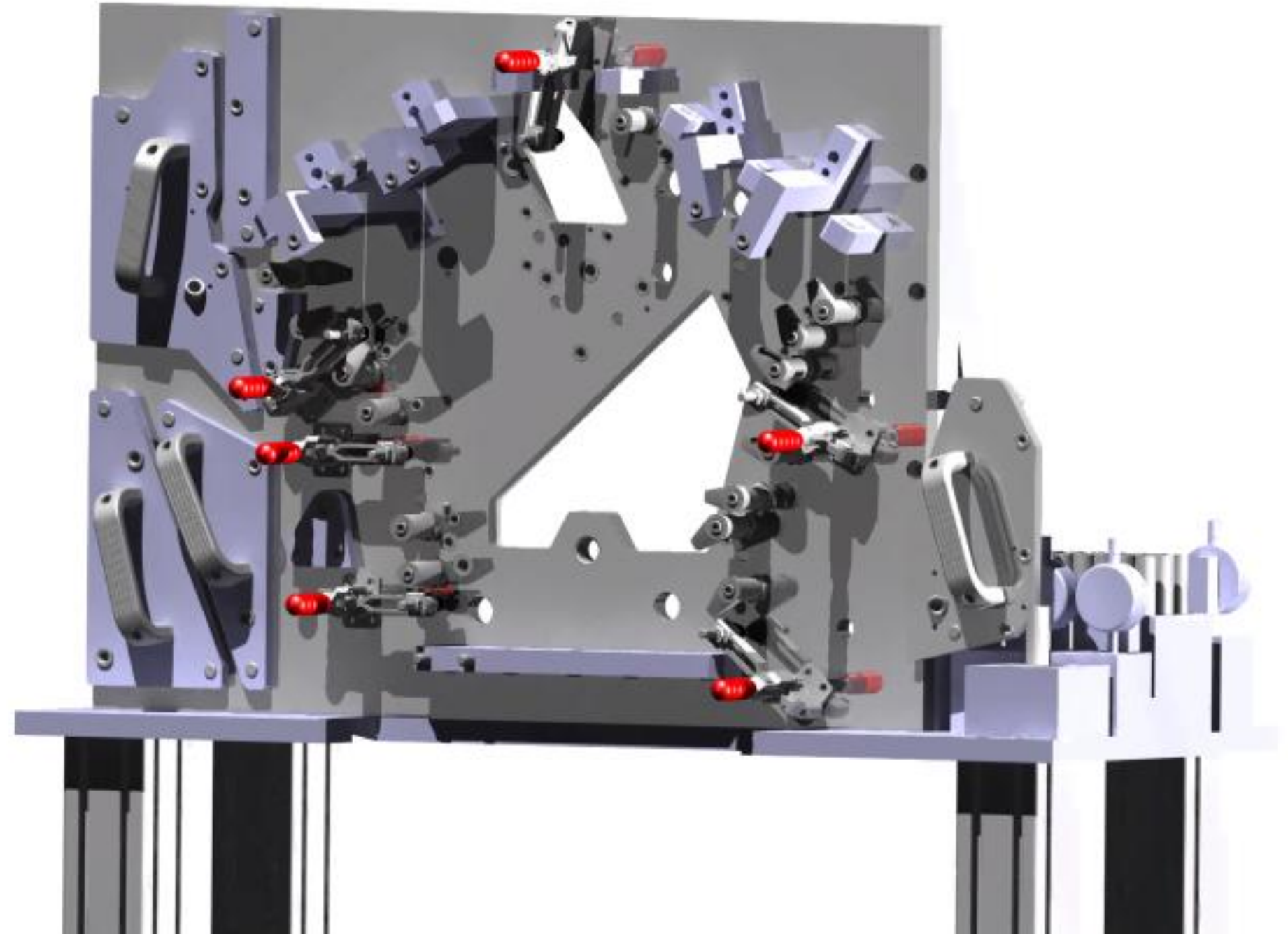

Work experience

- Ceat has as company differentiator the quality of the tools based on the experience selling quality equipment.
- Head count 21 employees
- Specialized head count designers, machining leader, automatization leader.
- We have and average of 10 years of experience.



Skills	Head Count	Experience
Designers	2	+ 8 years
Machining ops	3	+ 20 years
Assembly Mech	2	+ 25 years
Electricians	1	+ 20 years
PLC	2	+ 4 years
Pneumatic	1	+5 years
Project Manager	1	+ 7 years
Administrative	3	+ 25 years
Service engineer	2	+ 7 years
Sales representative	2	+ 7 years
Supply chain	1	+ 15 years
CMM Tech	1	+ 15 years
Total	21	

Design and manufacturing engineering

- 2 Designers with over 8 years of experience designing tooling
- Solid works design software
- 2 licenses.
- Simulation outsourced

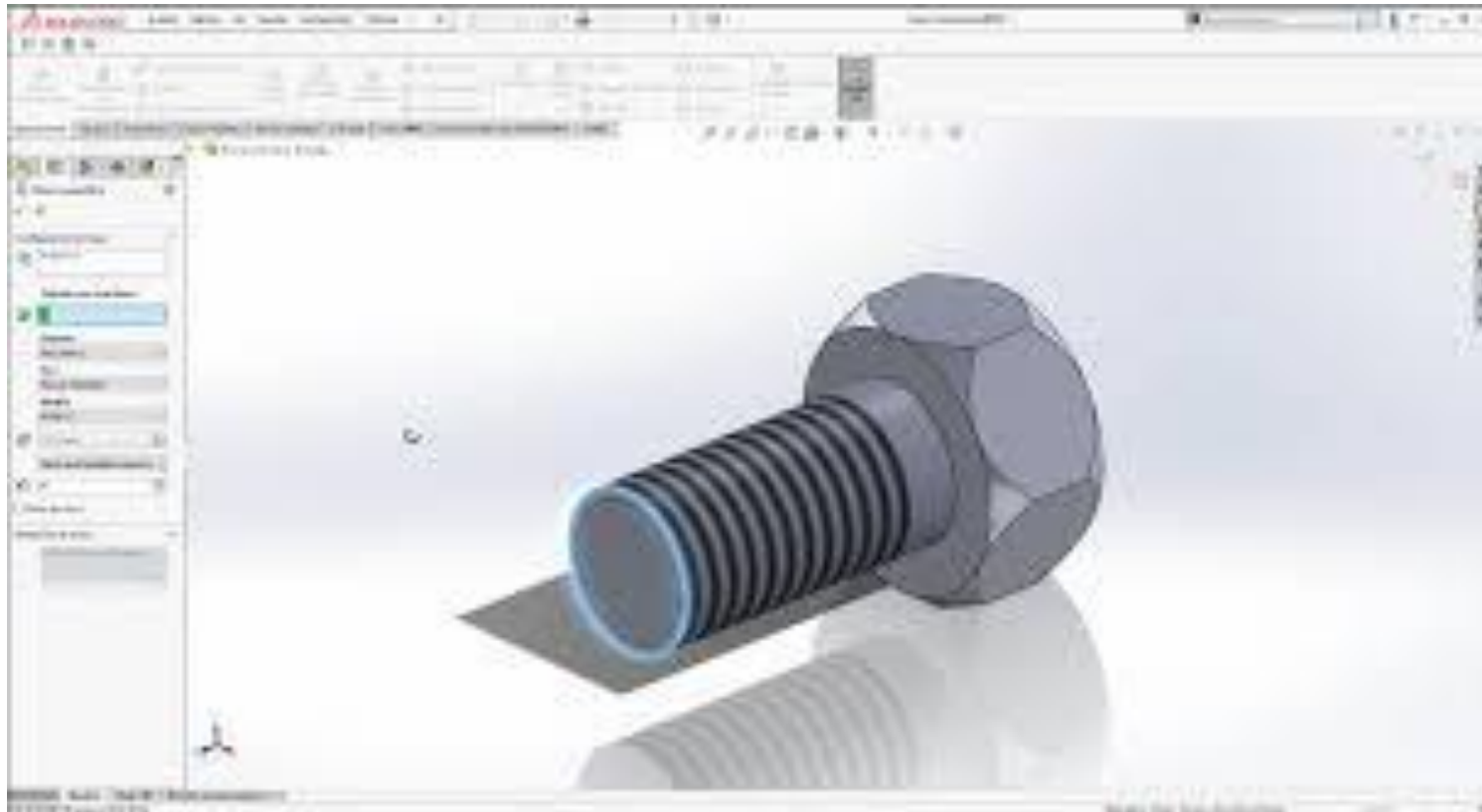

 **SOLIDWORKS**

Manufacturing Machinery & Equipment

#	Manufacturing equipment	Description	Table Size
1	DMG MORI MILLTAP 700 / MCLANE	CNC Vertical	30X20X20 "
1	CK6140S MCLANE	CNC Lathe	13 X40"
1	Titanium	Conventional Mill	40X20X15"
1	Plastic Injection	Plastic Injection	160 Tons



Assembly & Tech Equipment

- 2 Mechanical Assembly expert
- 1 Pneumatic expert
- 1 Electrician
- 2 PLC programmers
- They are in charge of the full assembly of the tools produced with an average of 13 years of experience
- Several assembly tools:
 - Manual drills.
 - Wrenches.
 - Working benches
 - Manual grinders.
 - Pneumatic moto tool.
 - Manual assembly tools
 - Manual gages



Quality Equipment

#	Equipment	Descriptions	Brand
1	Laser Tracker	0.035 mm repeatability	Leica
Several	Manual gauges		Mitutoyo, T&O
1	Ultrasound thickness gauge	0.1 mm repeatability	Karl Deutsch
1	Linear Laser	1 mm repeatability	Bosh
1	Eddy Current Crack detector	0.2 mm – below coating	Foerster



Brands



KARL DEUTSCH

- Eddy Current Testing
 - Crack inspection
 - Hardness Testing
 - Case Depth inspection

- Ultrasound systems
- Magnetic Particles
- Penetrant Liquids



Portfolio

- ECT Hardness Tester (5)

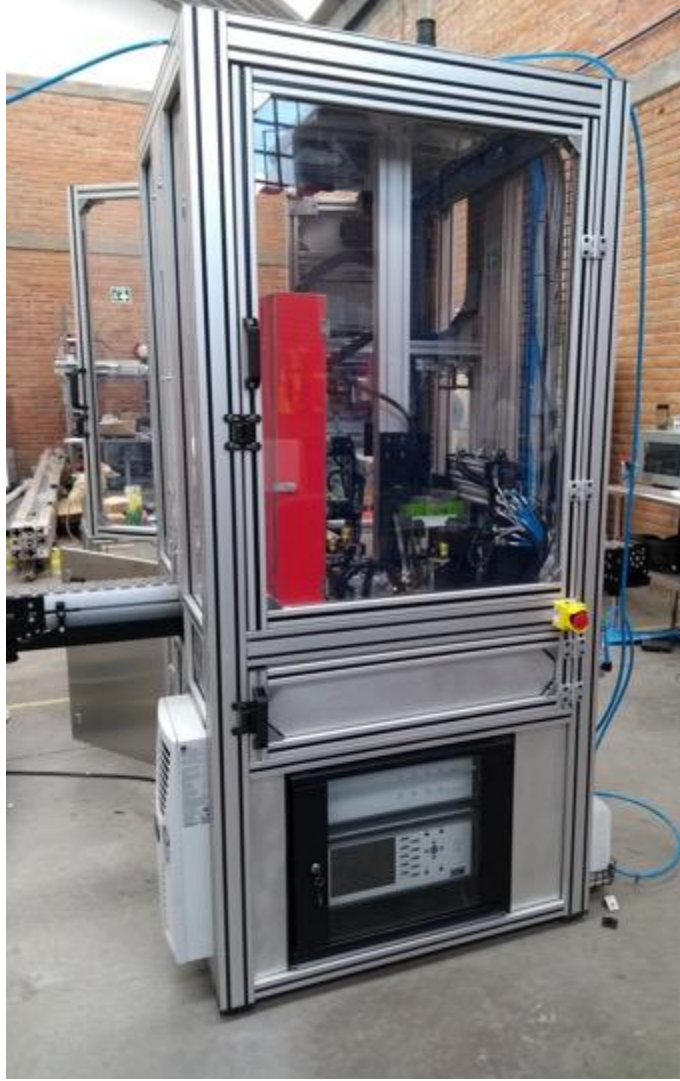

Portfolio

- Crack Detector of valves with Eddy Current and Ultrasound

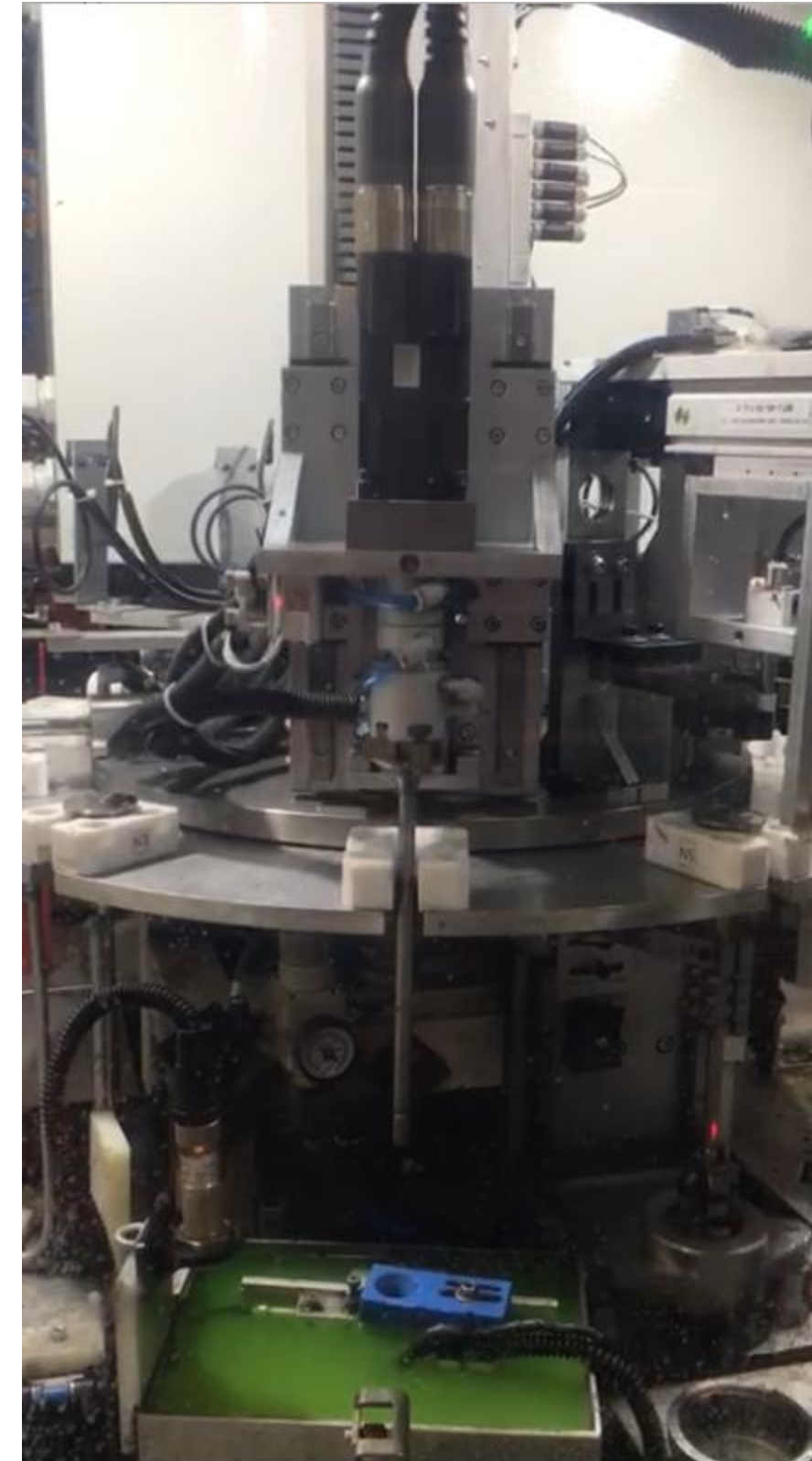

Portfolio

- ECT Crack Detector

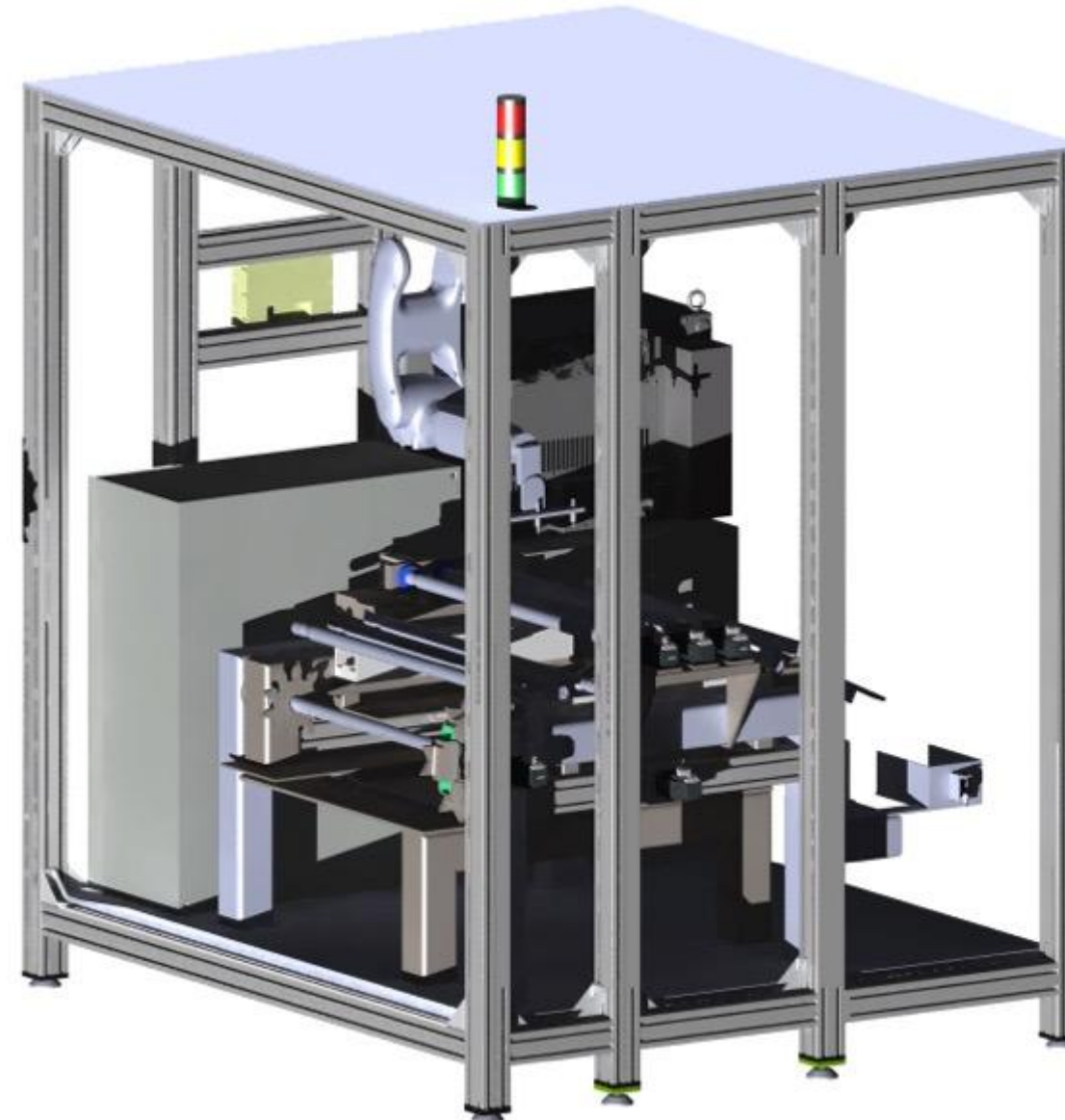
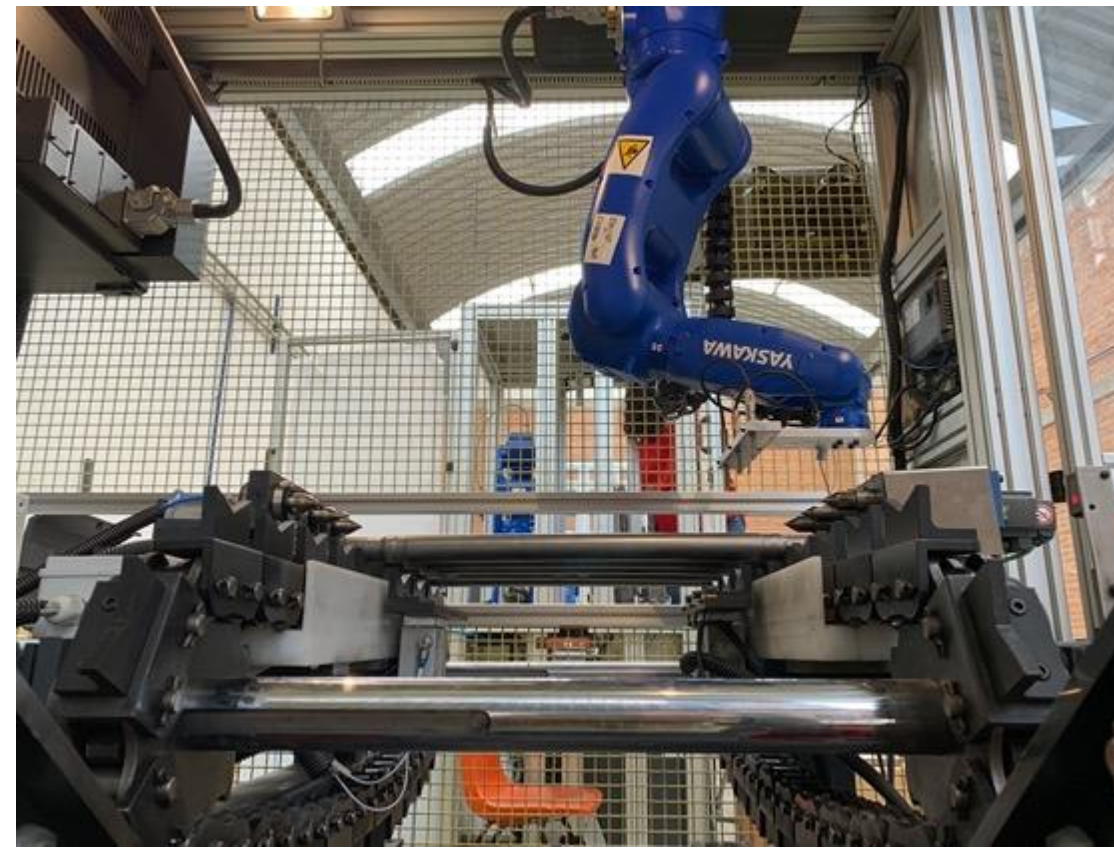

Portfolio

- ECT Hardness Tester (2)



Portfolio

- ECT Alloy Mix Tester (2)

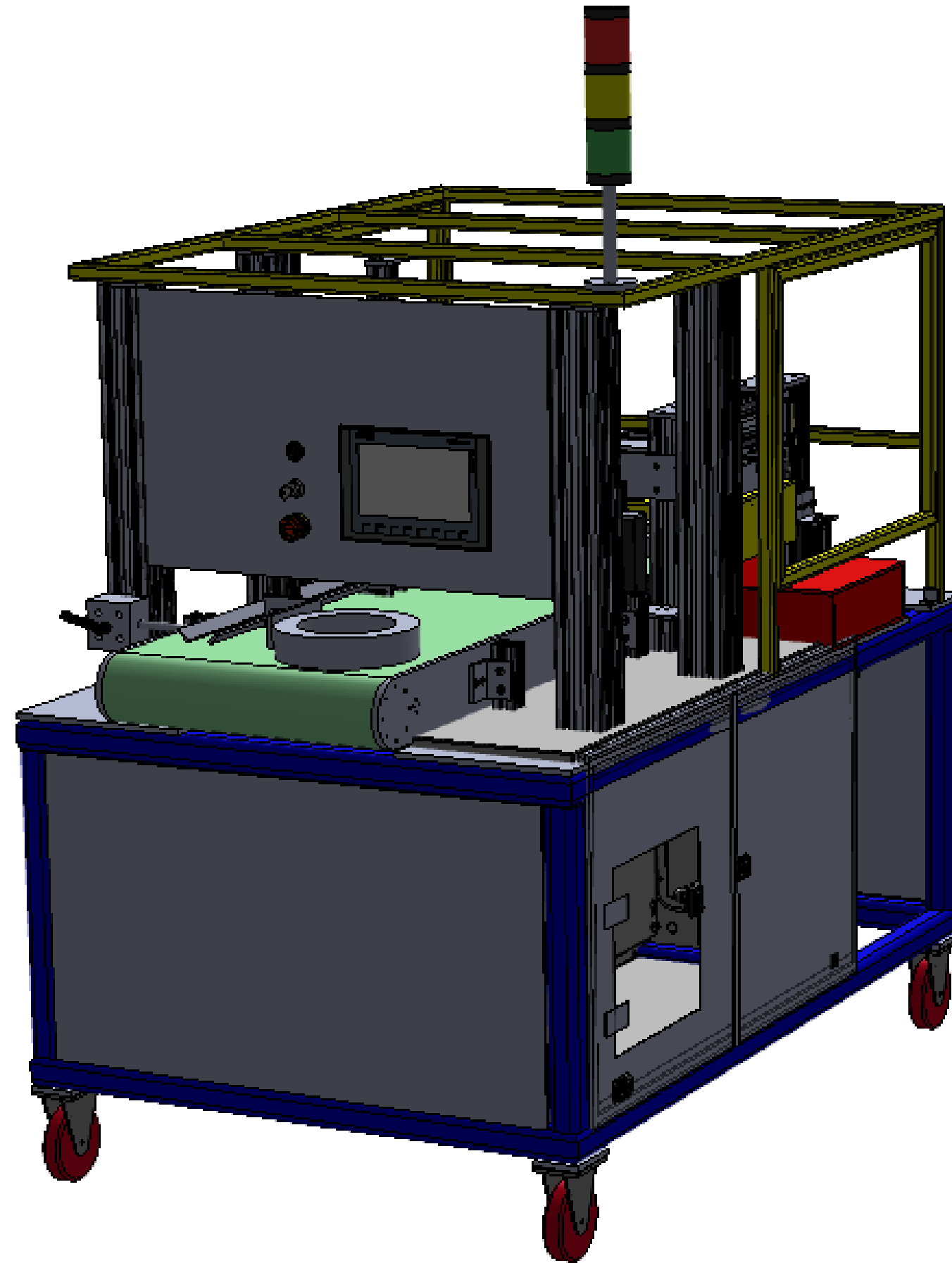

Portfolio

- Manual Crack Detector



Brands



- Automation Systems
- Fixtures
- Welding cells
- Robotic integrations
- Manufacturing – welding, assembly
- Machining – drilling, lathe, milling



Portfolio

- Checking fixture (2)
- True hole position between holes.

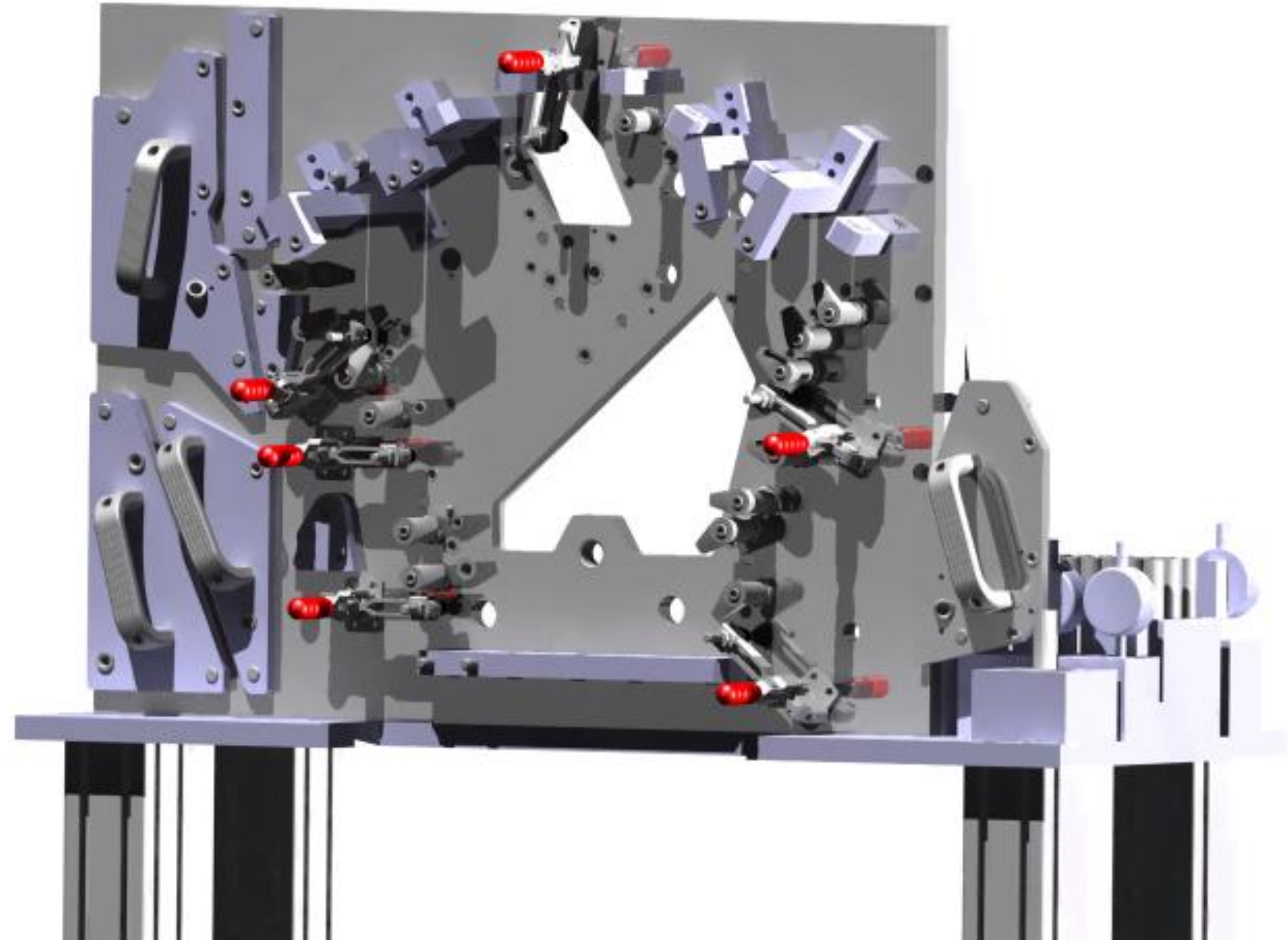

Portfolio

- Checking fixture (7)
- Holes and profile

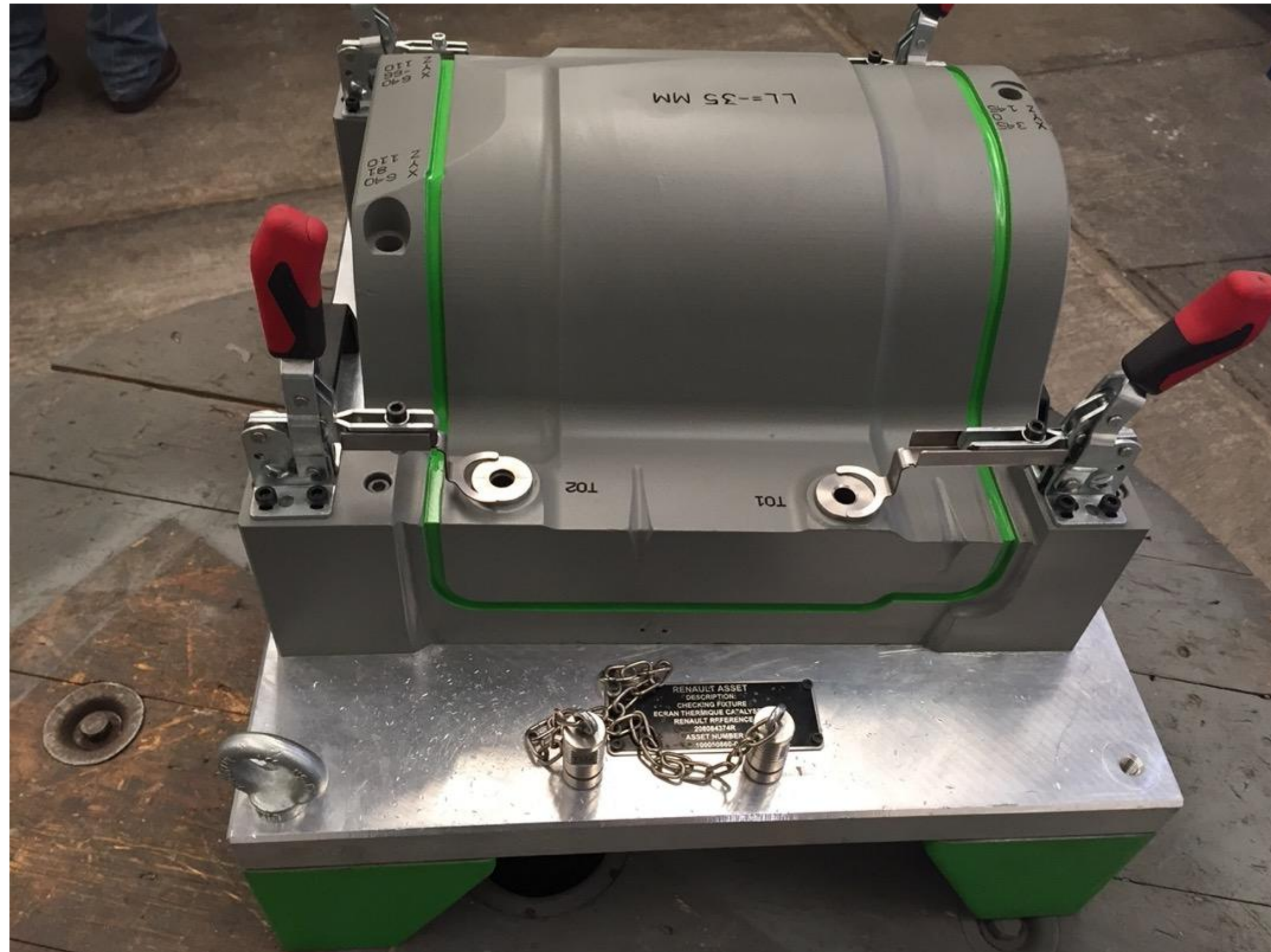

Portfolio

- X-Ray Segregation systems (2)

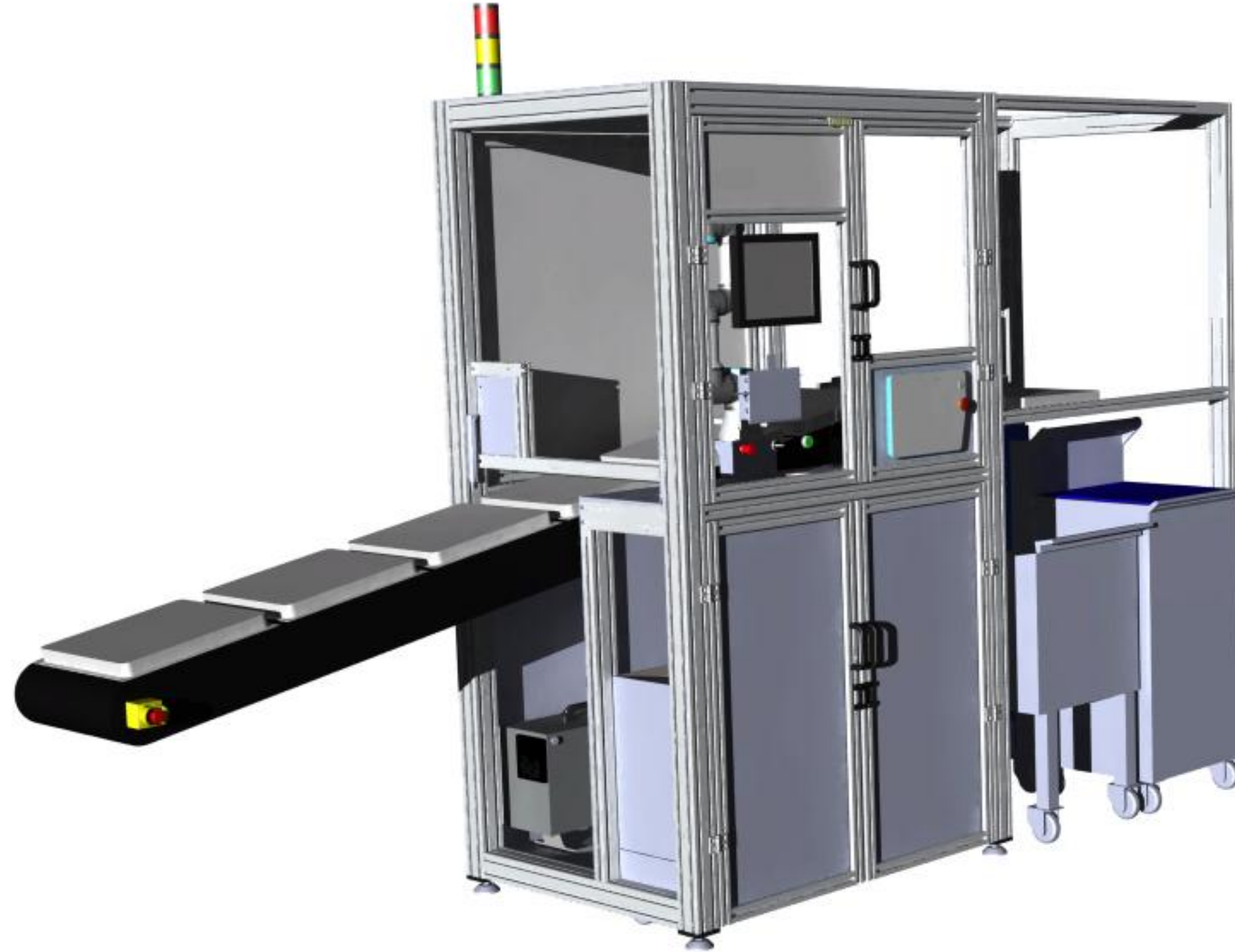

Portfolio

- Inspection line with visual system

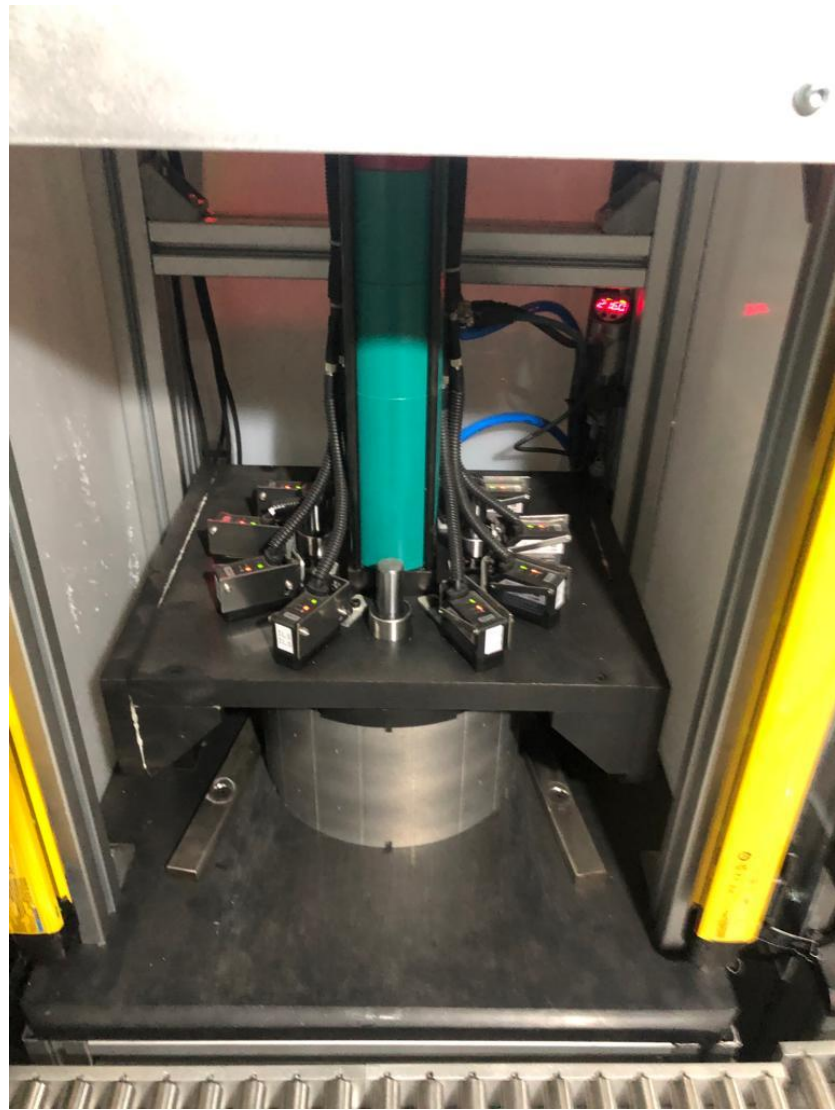

Portfolio

- Multistation for inspection, with Runout, Vacuum, Dimensional measures, Laser Marking, Paint Marking, Visual inspection and demagnetization unit.

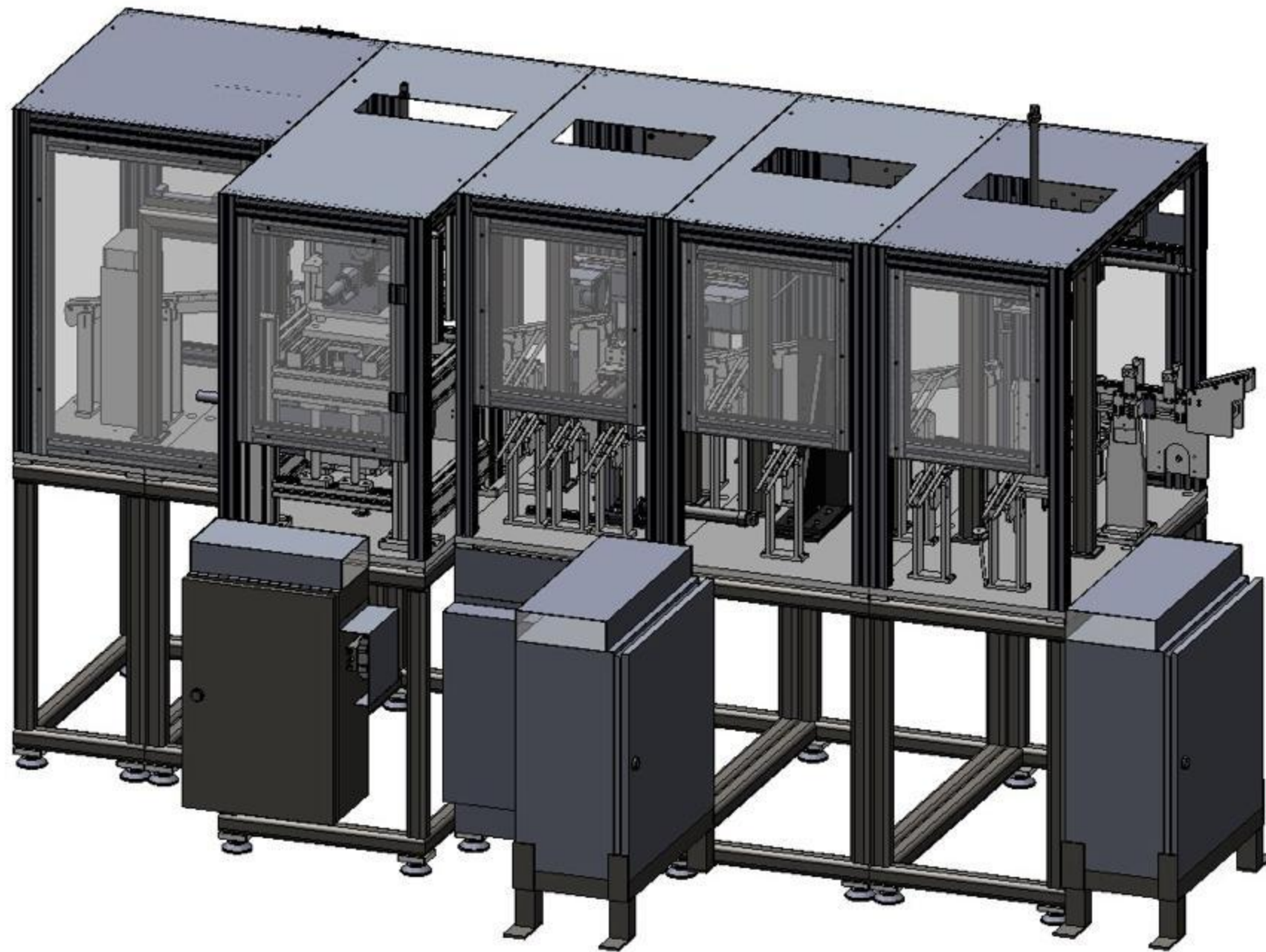

Portfolio

- Robotic Welding Cell



Portfolio

- Robotic Welding Cell

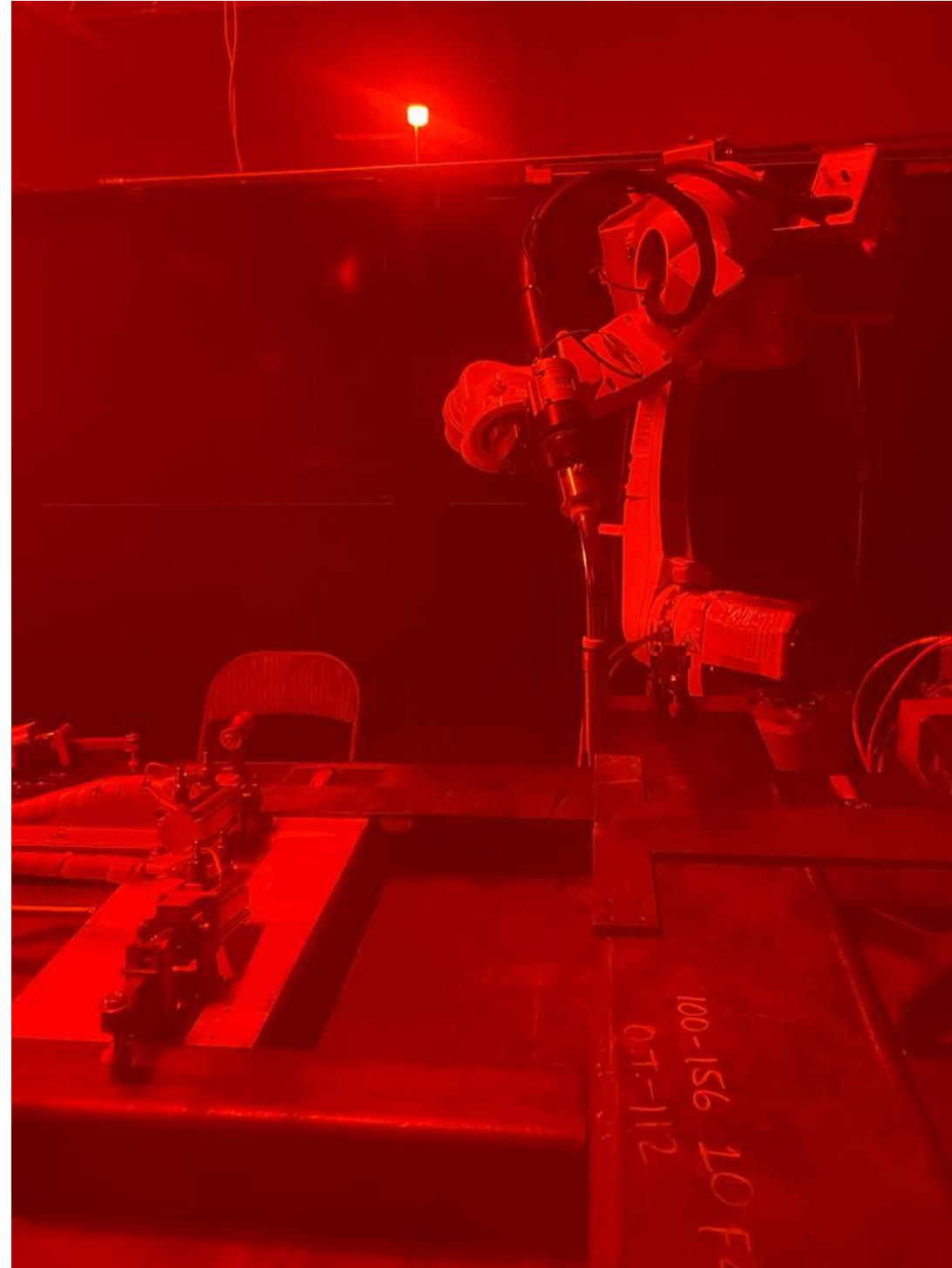

Brands



- Robot supplier and integrator



Brands



- Welding simulation with Augmented Reality.



Brands

THE X-RAY SOLUTION



- Industrial X-Ray Inspection and Automation



Brands

SECOPTA

Fast. Precise. Robust.

- Positive Material Identification (PMI) with Laser Induced Breakdown Spectrometry (LIBS)

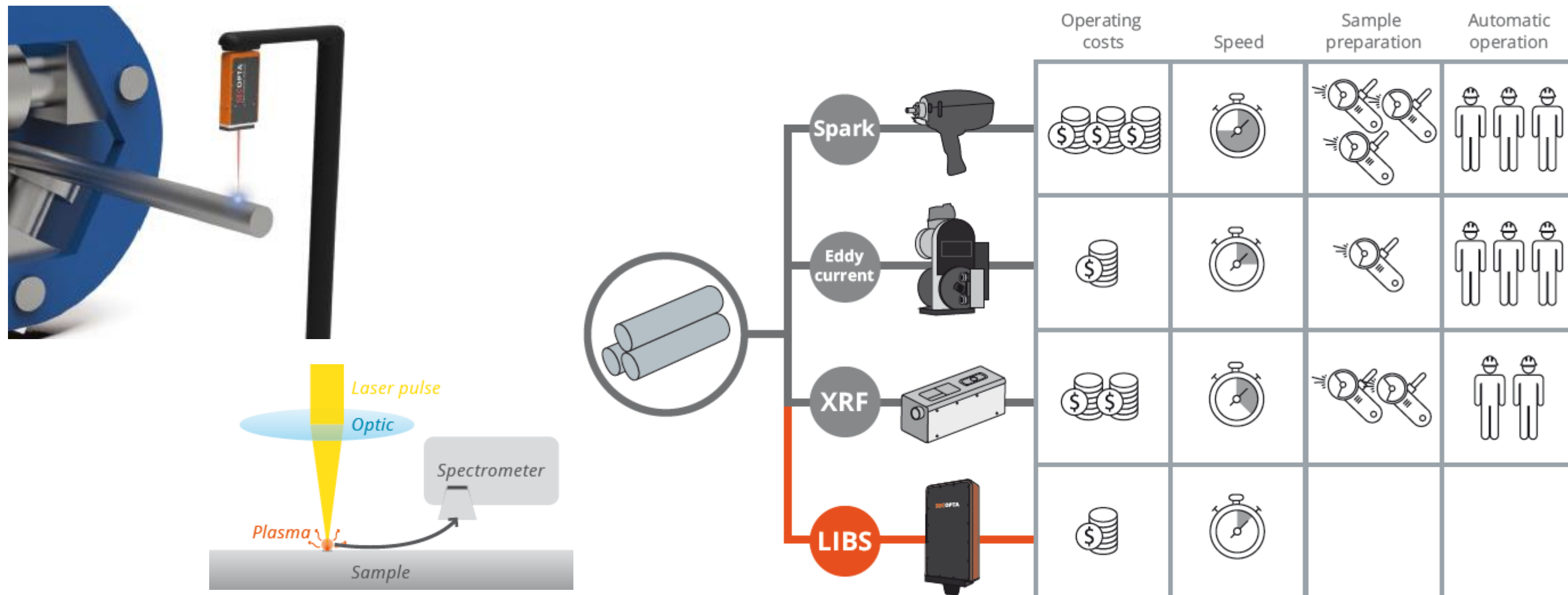

Comparing today's standard PMI approaches and the LIBS



Brands



- Electric Actuators.



Brands

ROKAE

- Robotic Solutions.



Brands



- Osung Midas – Muebles industriales



Supply base

SIEMENS

 **MISUMI**

 **SMC**

 **Carr Lane**
MANUFACTURING CO.

 **KEYENCE**

 **UNIVERSAL ROBOTS**

 **FESTO**

 **IIRSACERO**
S.A. DE C.V.

 **SOLDAMATIC**
AUGMENTED TRAINING FOR WELDING

YASKAWA

 **La paloma**
•Tu mejor aleación•

 **RACO**

 **TELEDYNE TECHNOLOGIES**
INCORPORATED

THK

THE X-RAY SOLUTION 

BALLUFF

BÖHLER UDDEHOLM

 **Kawasaki**

 **Hoffmann Group**

 **serviacero**
comercial

 **DESTACO**
a **DOVER** company

 **FOERSTER**

 **KARL DEUTSCH**

SECOPTA
Fast. Precise. Robust.

 **Coat**

Contact

Libramiento Sur Poniente Km. 13
Industrial Park – Los Angeles
Corregidora, Querétaro
México, ZP: 76928

Miguel Saldamando Rangel
Email: msaldamando@ceat.com.mx
Main Phone: 442-161-5011
Cell phone: 442-359-9646

