



ATSUMITEC DE MEXICO S.A. DE C.V.

**1**

**Company profile / Capital / Business partners**

**7P**

**2**

**Consolidated sales and number of employees /  
Sales composition overseas base**

**3P**

**3**

**Main production parts**

**8P**

**4**

**Environmental products**

**1P**

**Total 19P**

**1**

**Company profile / Capital / Business partners**

**7P**

会社概要 創立/資本金/主要取引先 その他

**2**

**Consolidated sales and number of employees /  
Sale composition overseas base**

**3P**

**3**

**Main production parts**

**8P**

**4**

**Environmental products**

**1P**



Founded

15<sup>th</sup> April 1949

Representative

Hideyuki Suzuki

Capital

310 Million yen

Business

Development,  
Manufacturing and Sales  
of Motorcycle, Automotive parts

Employee

3,630 (group)  
756 (domestic:Japan)

※Mar-23

Main Customer

-  Honda Motors
-  Mitsubishi Motors
-  Nissan Motors
-  Toyota Motors
-  Daihatsu Motors
-  Renault
-  Aisin
-  Aichi Machinery Industry
-  Univance
-  BMW
-  Kawasaki Motors
-  Yamaha Motors
-  Suzuki Motors
-  Musashi Seimitsu Kogyo

Domestic location

Head office: Takaoka plant



6-1 Takaokanishi Naka-ku  
Hamamatsu-shi, Shizuoka-ken  
《Technologies》  
•Other machines  
•PT Part assembly  
•Injection  
•Shifter assembly

Yuto plant (Development)



Ubumi 7111 nishi-ku, Yuto-cho  
Hamamatsu-shi, Shizuoka-ken  
《Technologies》  
•Press  
•Other machining  
•Heat treatment  
•Hard chrome plating  
•PT Parts assembly

Overseas

Atsumitec GR : 7 regions 9 facilities

※Jan-24

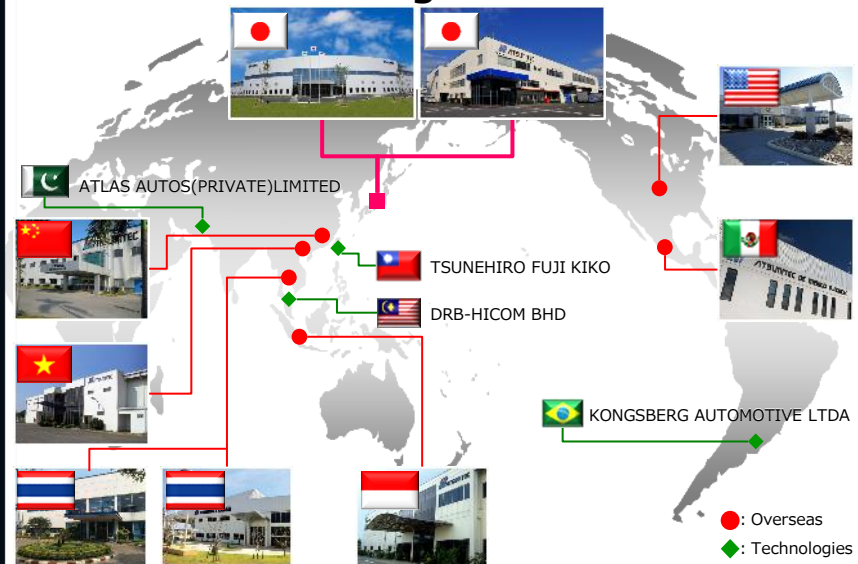



**Establish**

November.2013

**Mass Production**

November.2016

**Capital**

76.5 Million MXN  
(USD 3.6 Million)

**Our item**

Auto parts  
- Sewing  
- Assembly

**Associates**

85 people (Jan.2024)  
(With Japanese 1,  
American 1)

**Customers**



Nissan Mexicana



Ada Technologies Inc

**Space**

2,600m<sup>2</sup> (Apr.2023)

**Certification**

ISO 9001 2015  
2020.12

**Location**





# Organization Chart

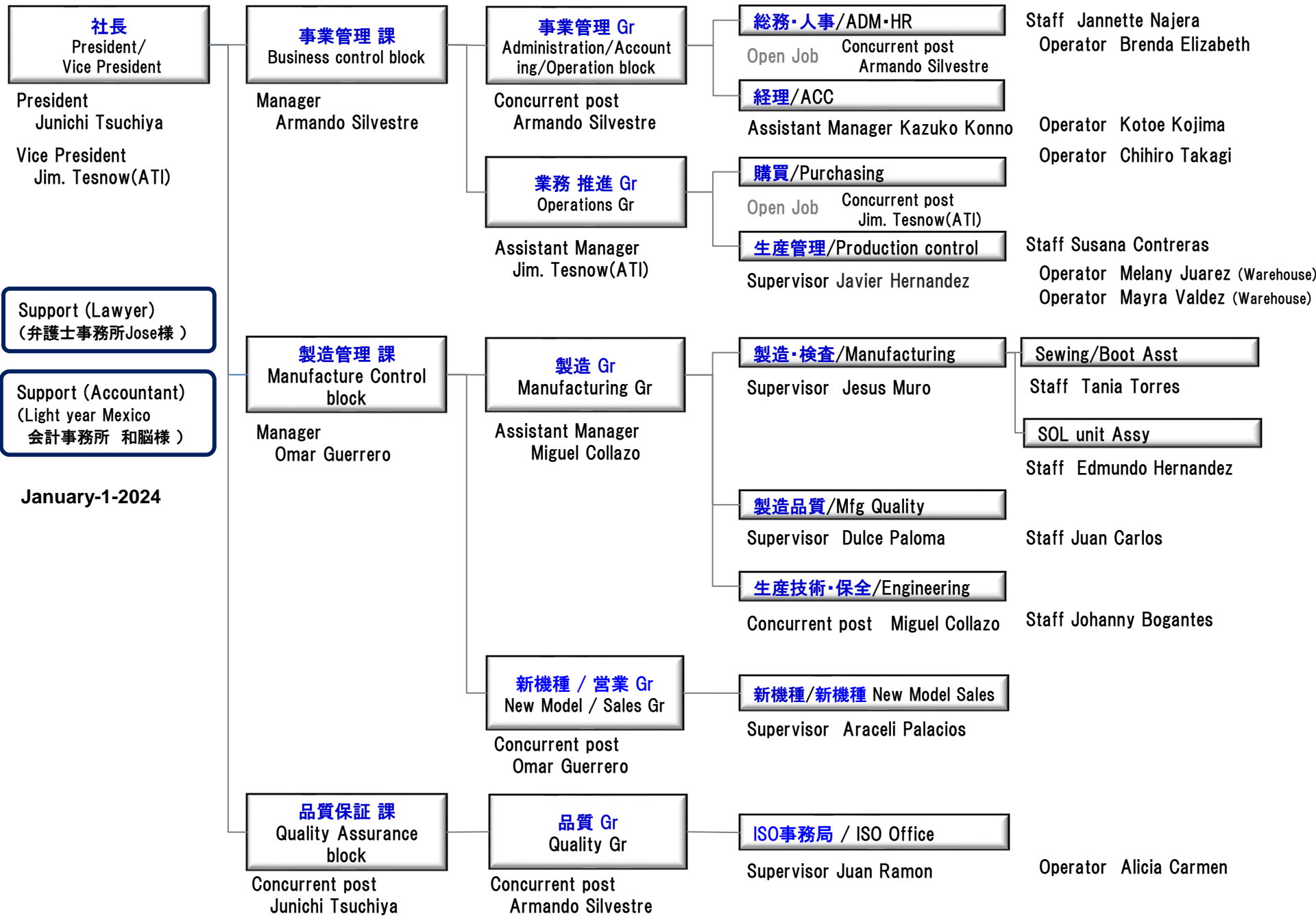



# Factory layout

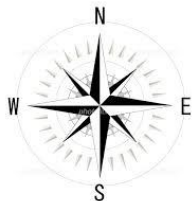

## Factory Area: 2,600m<sup>2</sup>

Not included the Toyota tsusho

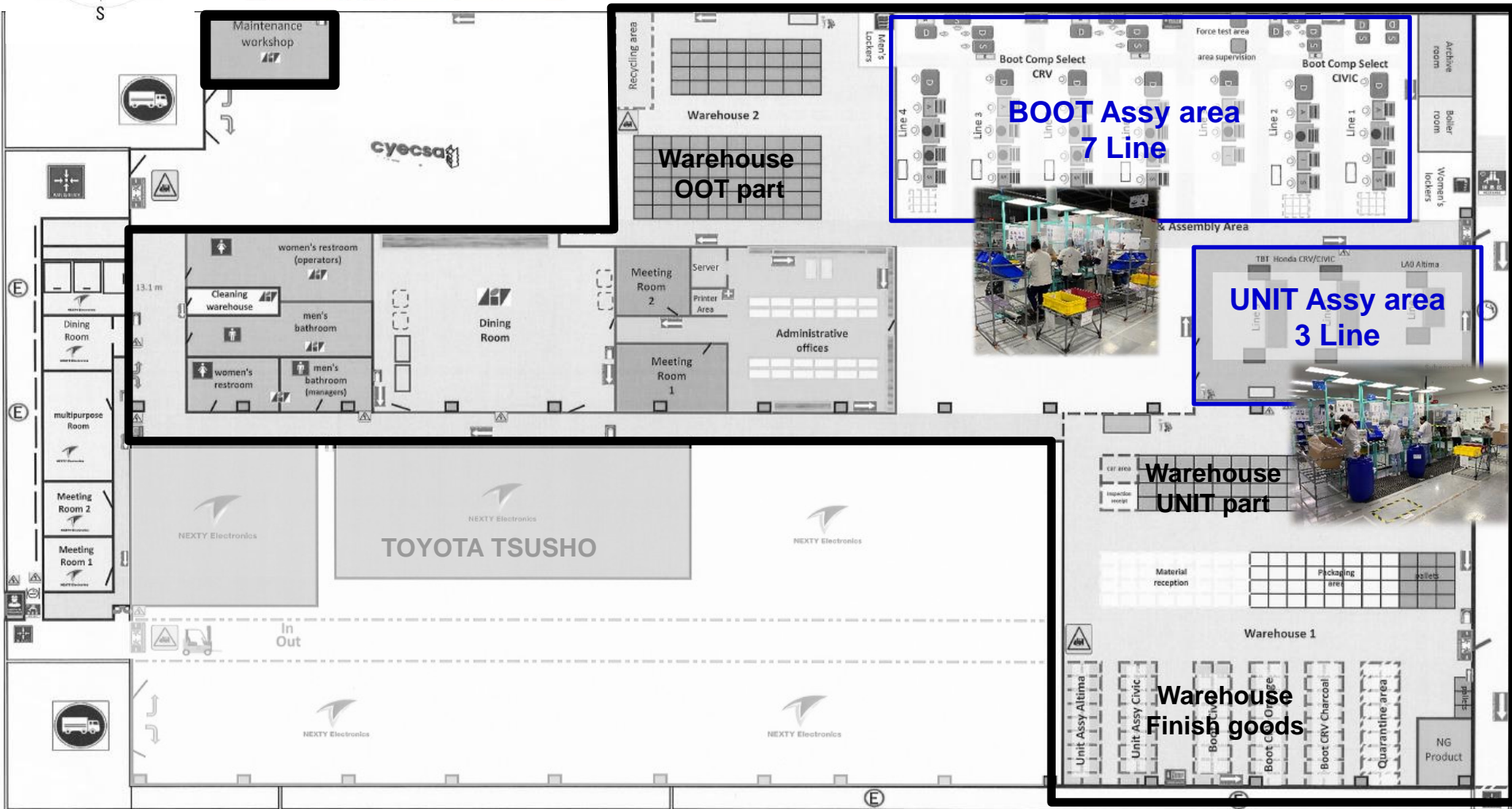



## Assembly

**Automation : 3 QA MACHINES**  
**Manual : 3 Lines**

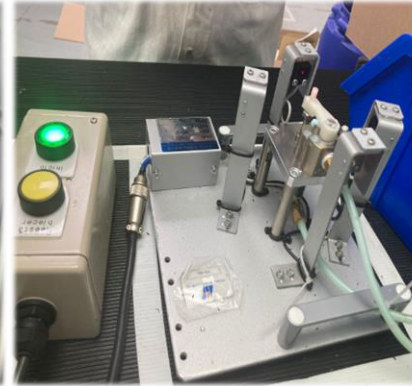
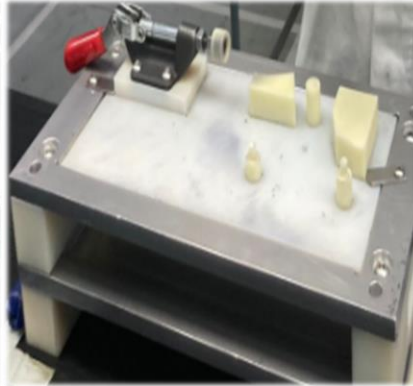
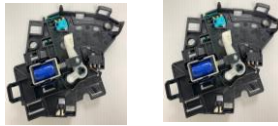

## Sewing

**Manual : 24 SEWING MACHINES**  
**Manual : 3 Lines**



## Assembly



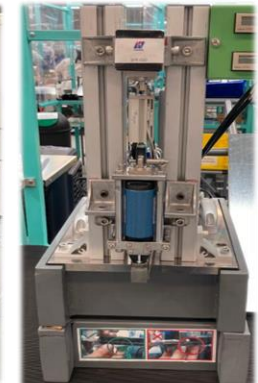









**Manual : 11 STAPLER MACHINES**  
**Manual : 7 Lines**



















## Current Mass Production

As of 2024 year plan

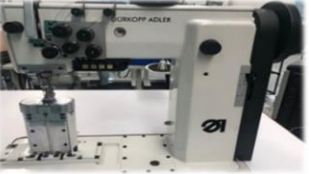
Parts		Customer	Car	Qty /month	Destination
	<b>DIRECT MT SHIFTER</b> 2019.12 build out		Frontier, NP300	9,000	Mexico, Chile, Brazil, Argentina, Peru, Costa Rica
	<b>UNIT Sol ASSY</b>		Altima	10,000	US(Canton)
	<b>UNIT Sol ASSY</b>		Civic	22,000	Japan(HMJ), US(IAP), Canada(HCM)
	<b>BOOT COMP SELECT</b>		Civic	22,000	Japan(HMJ), US(IAP), Canada(HCM)
	<b>UNIT Sol ASSY</b>		CRV	41,000	US(IAP,ELP), Canada(HCM)
	<b>BOOT COMP SELECT</b>		CRV	41,000	US(IAP,ELP), Canada(HCM)

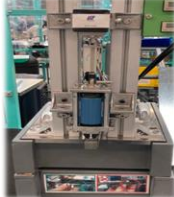
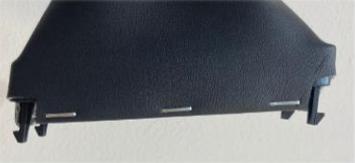
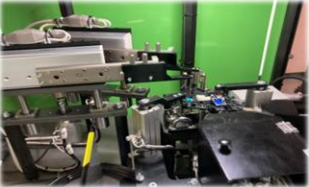

Maker		Specification		Possess
		Single stitch		7 Sewing machine
		Double stitch		15 Sewing machine
		Single stitch		1 Sewing machine
		Tower type double stitch		1 Sewing machine
Stapler machine (Atsumitec original)		Stapler machine		3 Assembly Lines
QA machine (Atsumitec original)		QA machine		3 Assembly Lines

1

Company profile / Capital / Business partners

7P

2

**Consolidated sales and number of employees /  
Sale composition overseas base**

3P

連結売上高及び従業員推移/海外拠点別 売上構成

3

Main production parts

8P

4

Environmental products

1P



※2W : Motorcycle

※4W : Automotive

※PT : Powertrain

## Atsumitec group (8country 10place)

<Simple sum>

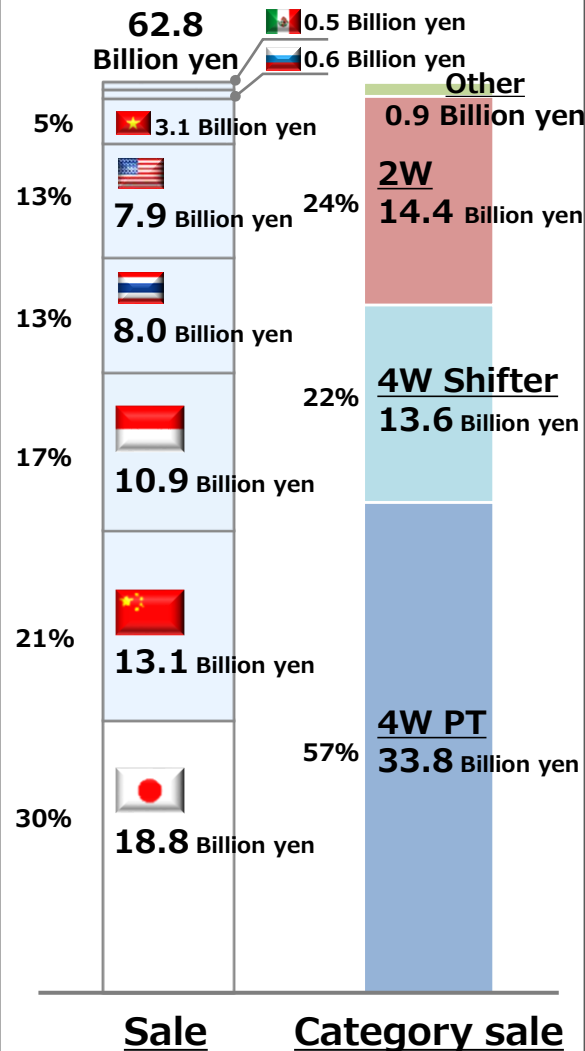

### 2W·Other → 4W-PT → 4W-Shifter

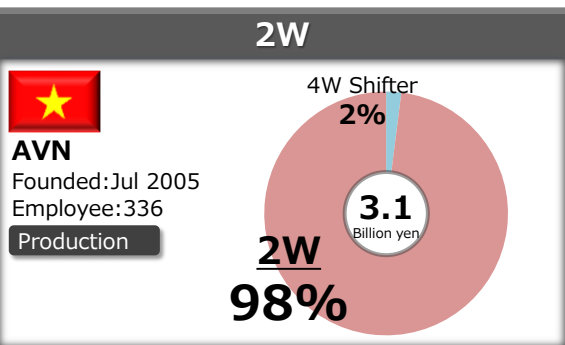
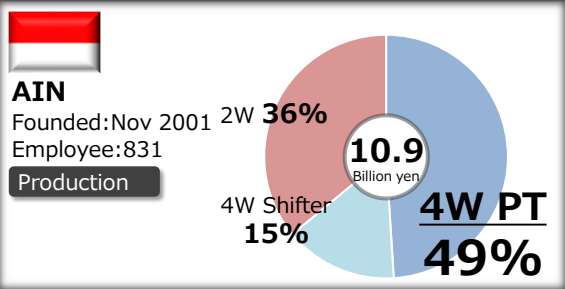
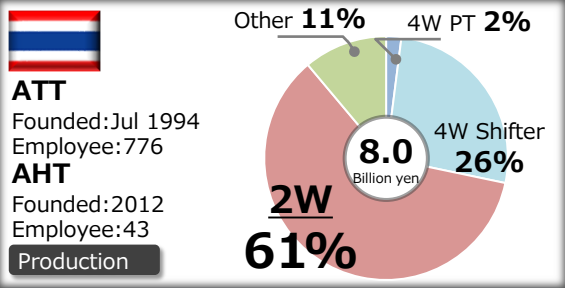
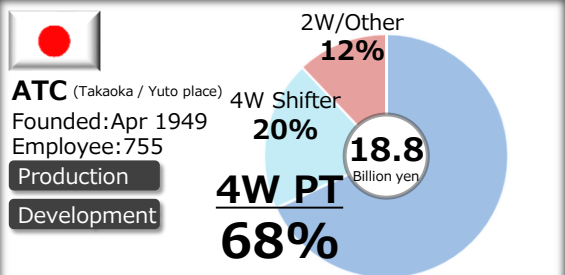

### 4W-Shifter → 4W-PT

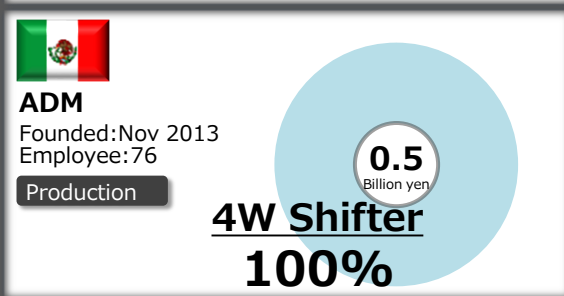
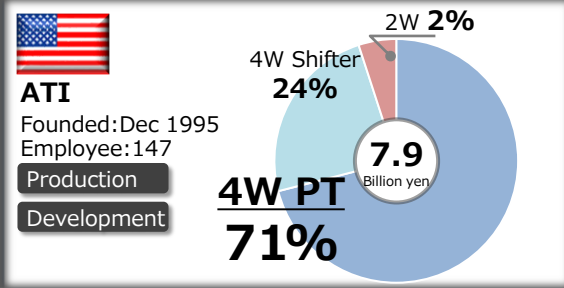
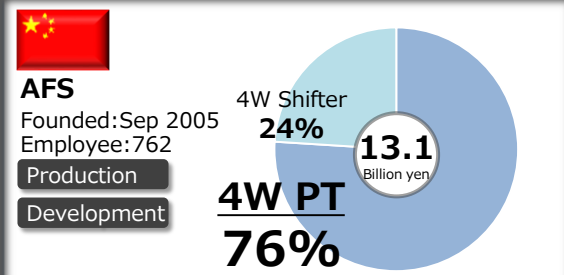



# Consolidated sales and number of employees

(Sale/100 million yen)

Atsumitec GR : 7 regions 9 facilities

(Number of person)

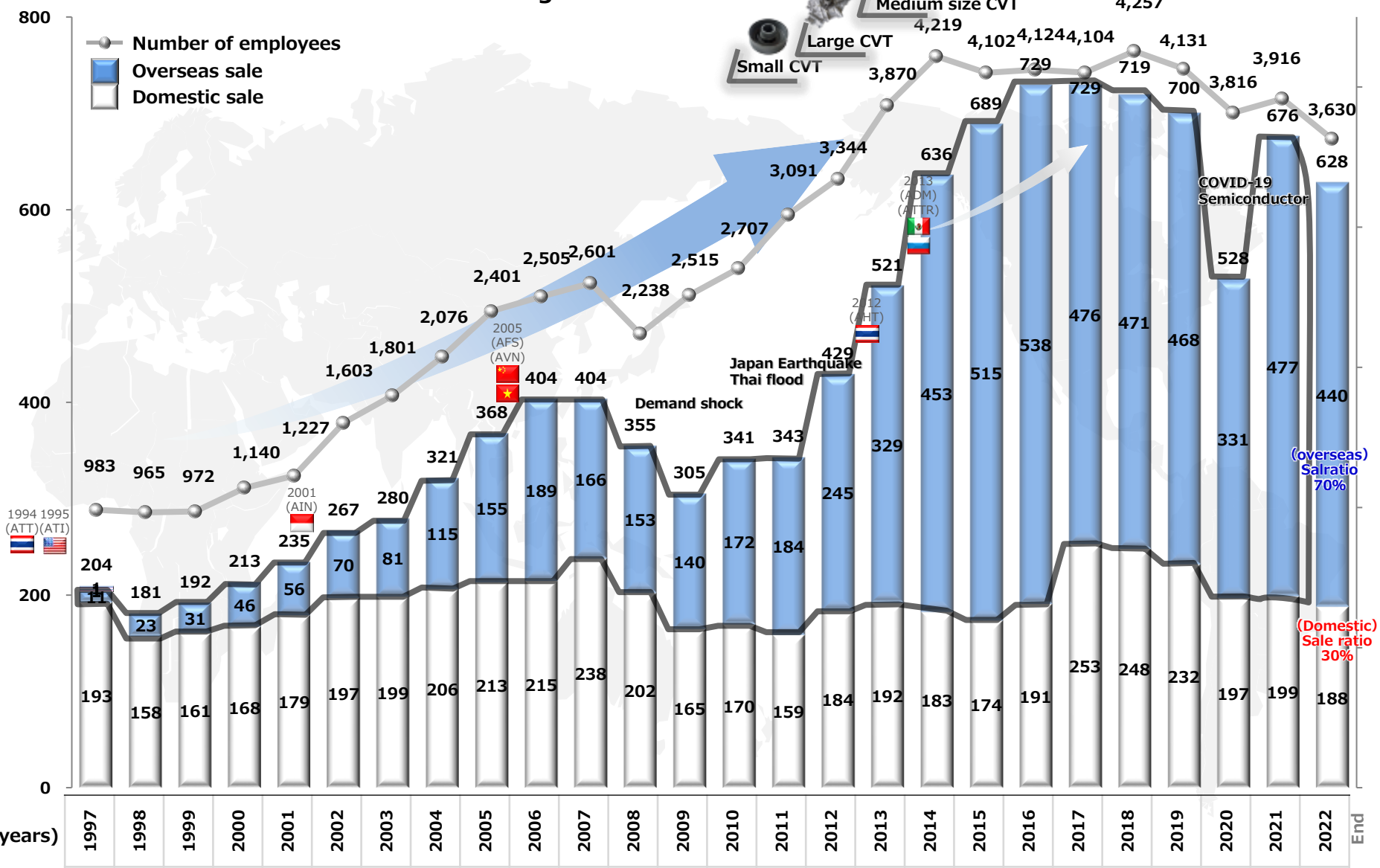

We have expanded sales by expanding our business in line with our customers' overseas expansion (increased production).

お客様の海外展開(増産)に追随した事業展開により、売上を拡大してきました



# Sales and number of employees

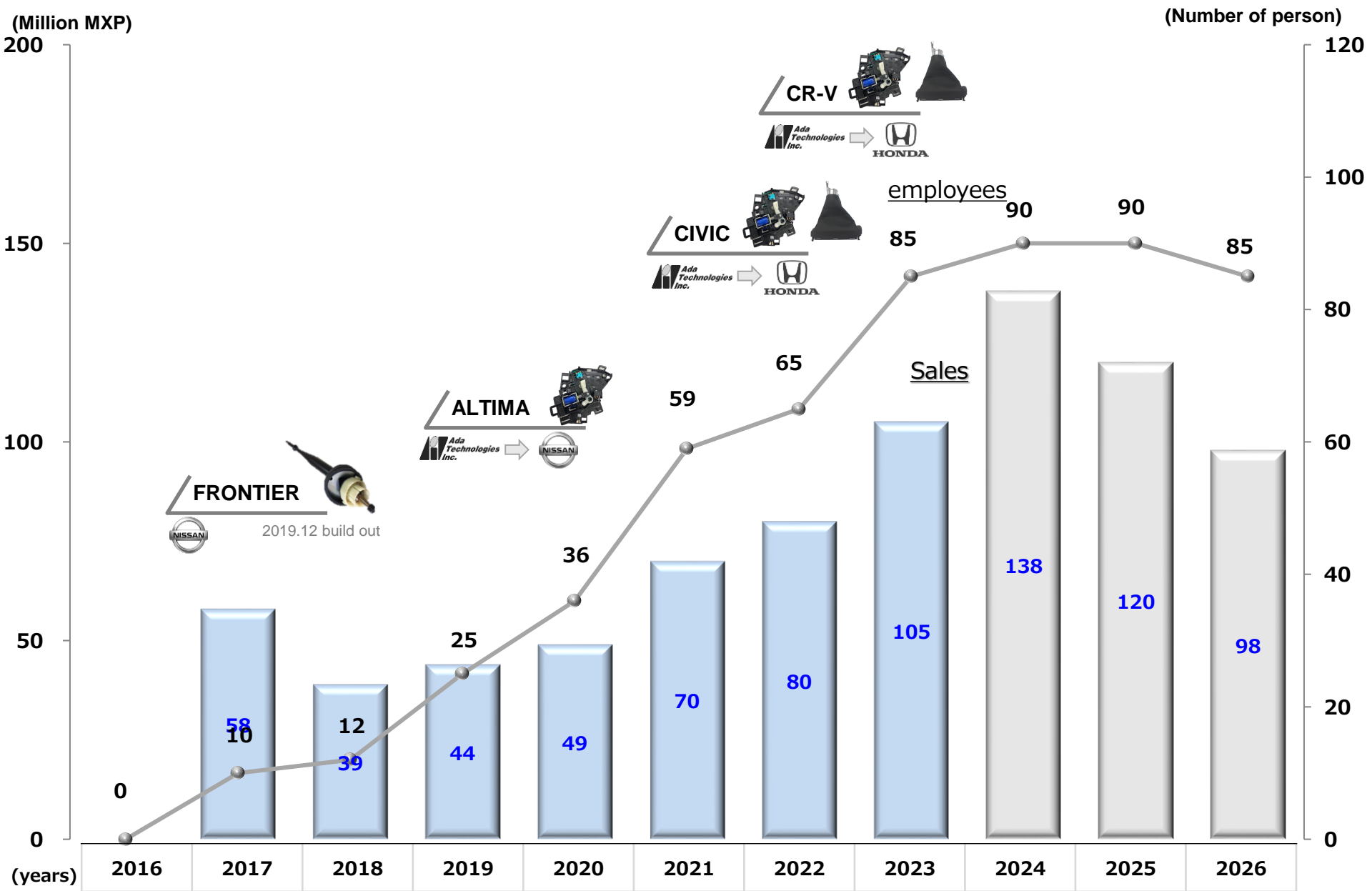

Increased workload with inter-group transactions.

グループ間取引で仕事量を増加

1

Company profile / Capital / Business partners

7P

2

Consolidated sales and number of employees /  
Sale composition overseas base

3P

3

**Main production parts**

8P

主力生産品目

4

Environmental products

1P

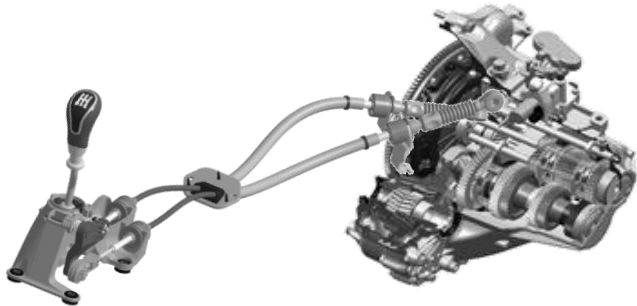

We have consistently developed and produced everything from knobs that you can touch with your hands to transmission parts that shift gears via cables.

We are a company that evolves the elemental technologies we have cultivated over our 70-year history into a wide variety of composite technologies and continues to provide new value to our customers.

<b>R&amp;D</b>	<b>Functional design</b>	Mechanism · Sensor · Resin · Steel + resin · Electric equipment
	<b>Design</b>	Lighting, decoration, electrical equipment, leather, soft resin
	<b>Analysis</b>	Strength · Operating load · Vibration · Flow
	<b>Test/Evaluation</b>	Strength, Operating Load, Shock, Vibration, Temperature Environment, Benchmarking
<b>Molding</b>	<b>Stamping</b>	Thin plate stamp 200t · Thick plate precision stamp 1000t · Thick plate precision stamp 1200t
	<b>Casting&amp;Forging</b>	Hot forging stamp, cold forging, aluminum casting
	<b>Resin</b>	Resin molding (insert, out-sert)
<b>process</b>	<b>Machining</b>	Cam-type special-purpose machine · Copy single-function machine · MC · NC lathe · Transfer MC
	<b>Welding</b>	Spot Projection CO2 Laser Plasma
	<b>Heat treatment</b>	Fixed Carburizing/Salt Bath/Batch Furnace/Continuous Furnace
	<b>Surface treatment</b>	Molybdenum thermal spraying, hard chrome plating, induction hardening
	<b>Complete</b>	
	<b>Assembly</b>	Press fitting, caulking, automatic assembly
	<b>Inspection</b>	Leak inspection/Function & Operation check/QA device · Welding condition monitoring device/QR system
	<b>Guarantee</b>	Shifter Function Assurance Maker Diagram · Mission Bench · Press Fitting Load · Operating Load

## - R&D -



Design/analysis



Various testing

## - Molding -



Resin molding



Stamping

## - Process -



Processing line



Heat treatment

## - Complete -



Automated assembly line



Measurement room





## TRANSMISSION

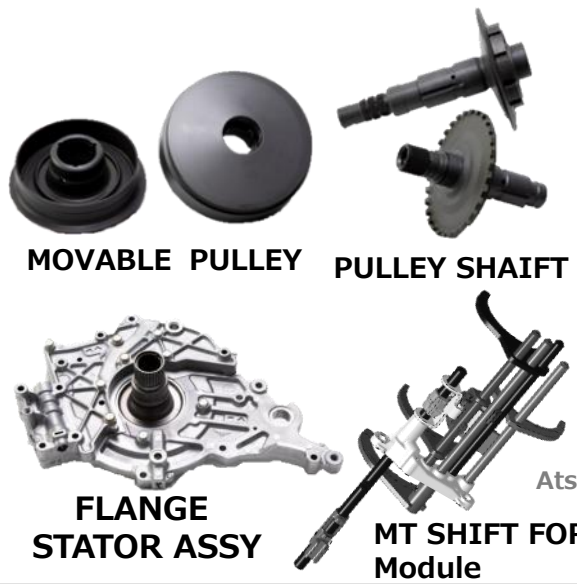

## SHIFTER

Atsumitec Original Development

	AT/CVT	MT
FLOOR		
IN PANEL		

ICE

HEV · BEV





**TRANSMISSION**



**FORK**

**DRUM ASSY**



**CONTROL SHAFT**

**KICK SPINDLE**



**ENGINE**



**CONNECTING ROD**

**SEPARATE CONNECTING ROD**



**BALANCER**



**Cultivator**



**SHIFT FORK SHAFT**



**DRIVE PLATE COMP**



**ALUMINUM CONOD**

**BALANCER**



**ARM VALVE**



**Generator**

Motorcycle

POWER PRODUCT

## <4R Shifter Parts>

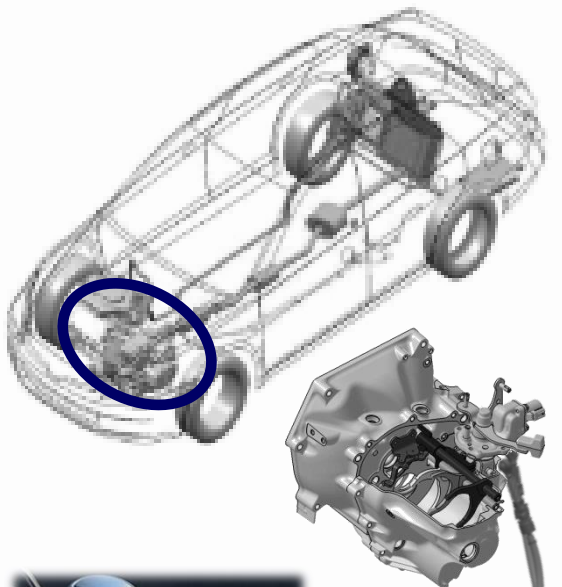

## <Boot Select Comp>

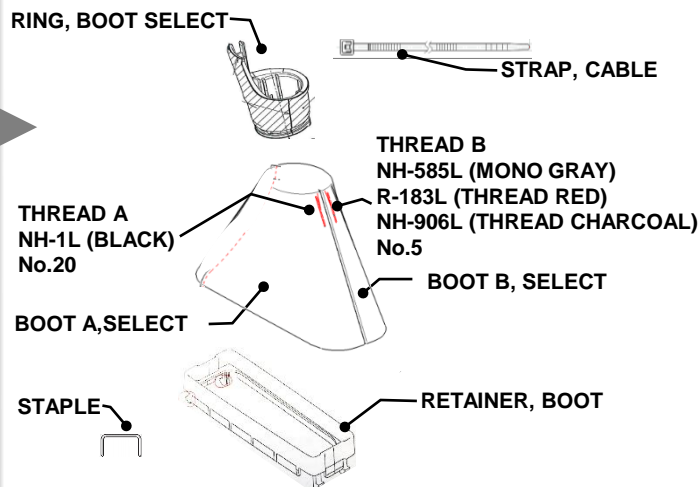

## <UNIT Assy Shift Lock>

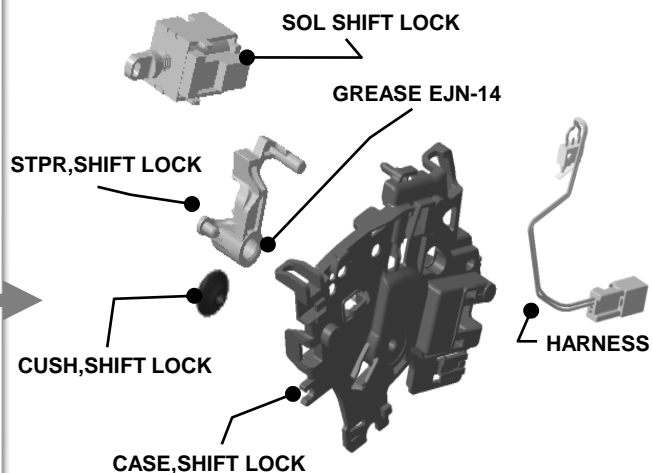



## Sewing armed of products and accessories



HEADREST COVER



SEAT COVER



BELT COVER

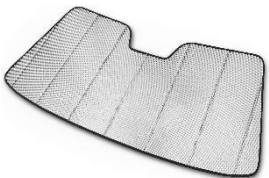

CAR SUN COVER



CAR CURTAINS



CAR CARPET MATS



SINGLE STITCH



DOUBLE STITCH

## Products with decorative sewing (double stitch)



SIDE REST



SIDE REST



CONSOLE LID







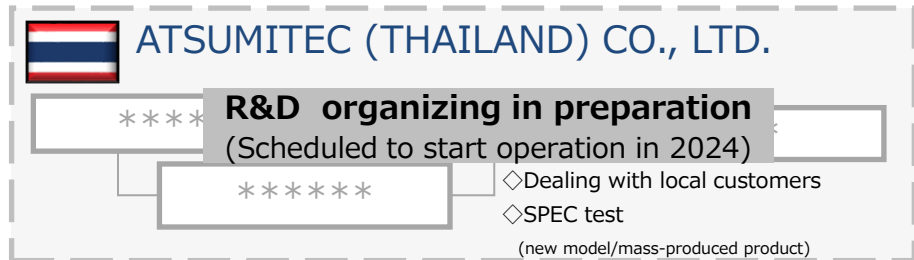
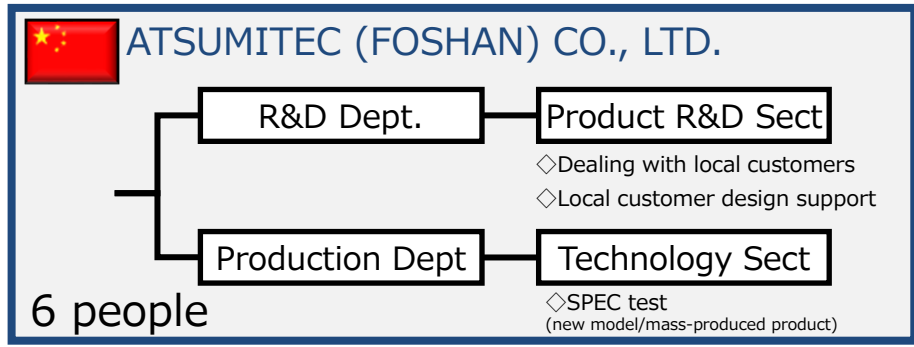
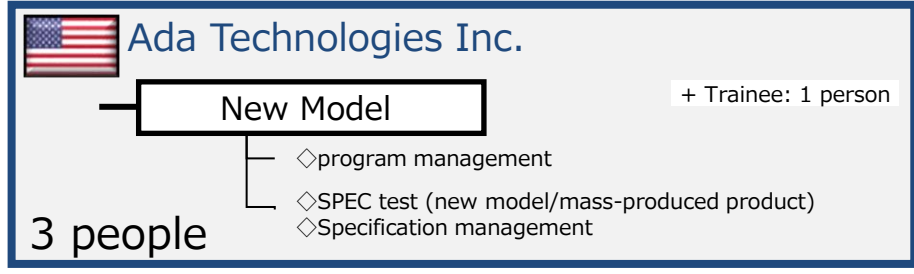
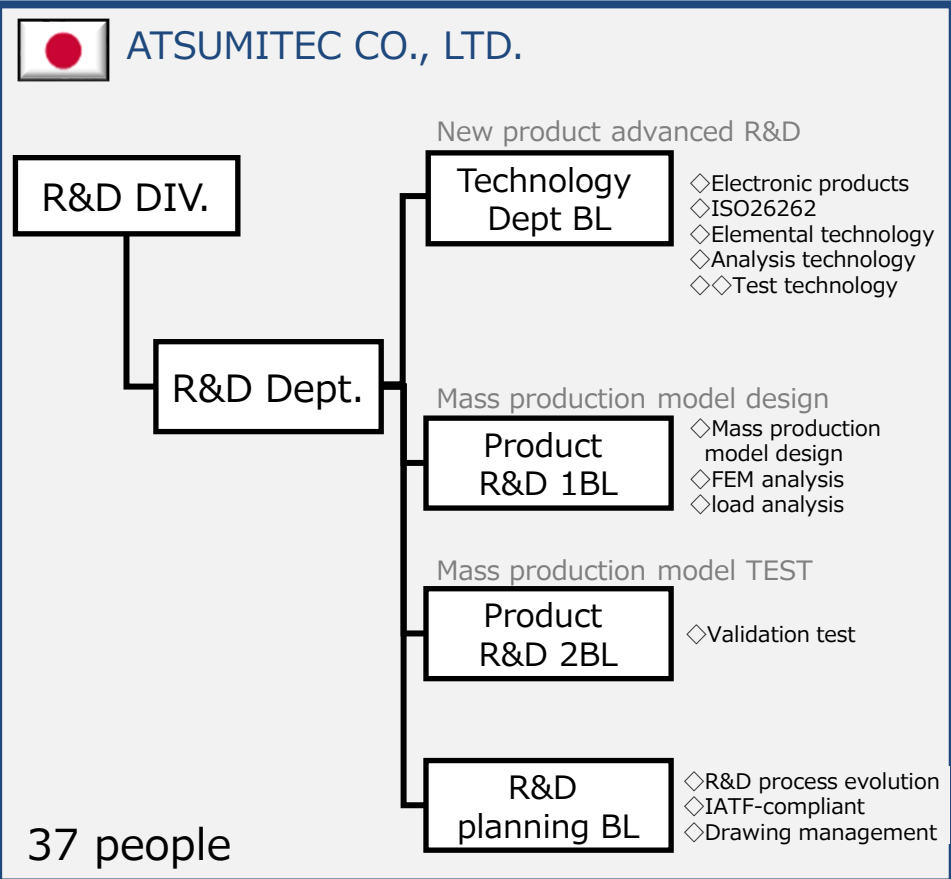

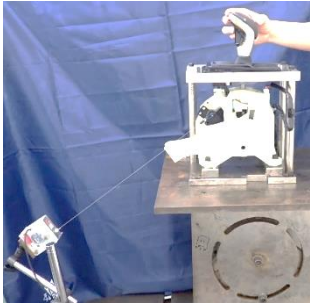

LEG SUPPORT

Development system



Regardless of resin or iron products, we are expanding globally from design to analysis and actual machine testing.

## Equipment (Merchantability/strength item)

<p>Merchantability test bench</p>  <p>Operating load, Backlash stroke measurement</p> <p><b>5</b> units</p>	<p>Merchantability measurement robot</p>  <p>Operating load, Backlash stroke measurement (automation/stabilization)</p> <p><b>1</b> unit</p>	<p>Anechoic chamber</p>  <p>Sound pressure/ sound quality measurement (background noise 25dB or less)</p> <p><b>1</b> room</p>
<p>Lighting test room</p>  <p>Luminance/ chromaticity Measurement (0.05cd~100cd)</p> <p><b>1</b> room</p>	<p>Autograph(5,000N)</p>  <p>PUSH load, RLS load measurement (5kN MAX)</p> <p><b>1</b> unit</p>	<p>Strength tester</p>  <p>AT/MT select intensity (2kN MAX)</p> <p><b>5</b> units</p>
<p>Autograph(50,000N)</p>  <p>shifter strength, shift fork strength (50kN MAX)</p> <p><b>1</b> unit</p>	<p>Impact tester(50,000N)</p>  <p>Shifter impact strength (50kN MAX)</p> <p><b>1</b> unit</p>	<p>Fatigue tester</p>  <p>Shifter fatigue strength, Shift fork fatigue strength (±10kN)</p> <p><b>2</b> units</p>

## Equipment (durability/environmental items)

<p>Constant temperature/humidity bath</p>  <p>Durability of resin parts (-40°C~150°C) (95%RH)</p> <p><b>9</b> units</p>	<p>Heat shock tester</p>  <p>Durability of resin parts (-40°C~200°C)</p> <p><b>1</b> unit</p>	<p>Dust tester</p>  <p>AT/MT dust resistance (Compliant with JIS standards)</p> <p><b>1</b> unit</p>
<p>Vibration resistance tester</p>  <p>AT/MT vibratory (80G MAX)</p> <p><b>1</b> unit</p>	<p>Endurance robot</p>  <p>AT/MT durability (Automation)</p> <p><b>4</b> units</p>	<p>Abrasion tester</p>  <p>Abrasion resistance of decorative parts (Compliant with JIS standards)</p> <p><b>1</b> unit</p>
<p>T/Miss test machine 1</p>  <p>MT shifter + T/Miss feeling)</p> <p><b>1</b> unit</p>	<p>T/Miss test machine 2</p>  <p>Shift fork Forced sync test</p> <p><b>1</b> unit</p>	<p>Electronic test chamber</p>  <p>SBW/electronic component testing (Class 5)</p> <p><b>1</b> room</p>

1

Company profile / Capital / Business partners

7P

2

Consolidated sales and number of employees /  
Sale composition overseas base

3P

3

Main parts

8P

4

Environmental products

1P

環境商品



Carbon Neutral 実現に向けて 地球に優しいエネルギーを開発

## Developing Earth friendly energy for the realization of Carbon Neutral

### ① <Visible Hydrogen >

The film of hydrogen storage alloy  
**Product name : Suisoban**  
(Hydrogen detection sheet)



### ① <水素をみはる>

水素吸蔵合金を薄膜にした  
商品名 : スイズバン  
(水素検知シート)

### ② <Storage Hydrogen >

② <水素を貯める>



«Hydrogen adsorbent»

«水素吸着材/吸蔵材»

«Storage material»  
(Hydrogen storage alloy)

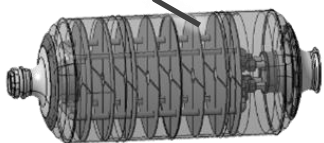

Ex: Car tank

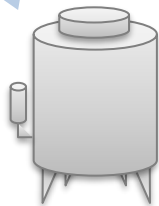

Ex: Stationary tank

### ③ <Utilize Hydrogen > (power generation)

③ <水素を使う(発電)>



«Fuel cell»



Ex: Portable generator



Ex: Drone

NEDO 産総研 RIKEN  
Atsumitec  
Technology to work on  
東北大学 九州大学 AIT  
TOHOKU UNIVERSITY KYUSHU UNIVERSITY 愛知工業大学

- Research and development improve hydrogen storage efficiency
- 水素貯蔵効率向上に向けた研究開発

- Development of practical technology for performance SOFC stack aiming at energy saving power generation
- 省エネ発電を目指した高性能SOFCスタックの実用化技術開発

**END**