

SANNOHASHI MANUFACTURING MEXICO SA de CV



May, 2024
Sales Department

One Century of Innovative Fastener Technology

1. Sannohashi Global Network
2. Main Global Customers
3. SMM Company Profile
4. SMM History
5. SMM Main Customers
6. Location in Mexico
7. Products

“SANNOHASHI close to the customers”

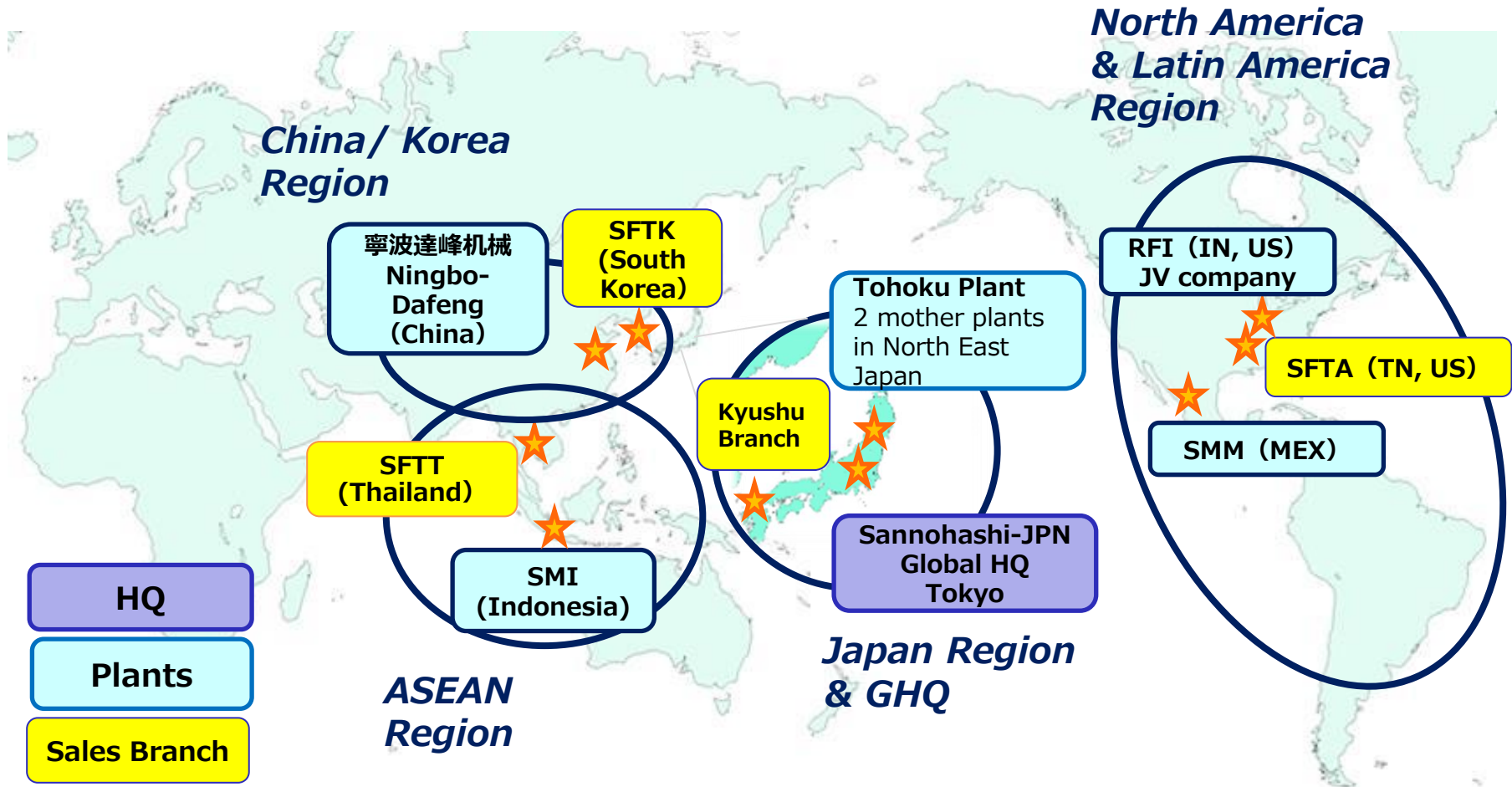

SMM support customers' Localization by "Made in Mexico" products

Sannohashi (JPN)
Head Quarter (Saitama)
Mother Plants (Tohoku)

RFI (Indiana)
J/V company in US

SFTA (Tennessee)
Full service trading company
Delivery center for US customers.

- Supporting Design & Quality function also.
- 2hrs. to VW Tennessee.

SMM (Guanajuato, central Mexico)
Manufactory Base for Localization (domestic and export).

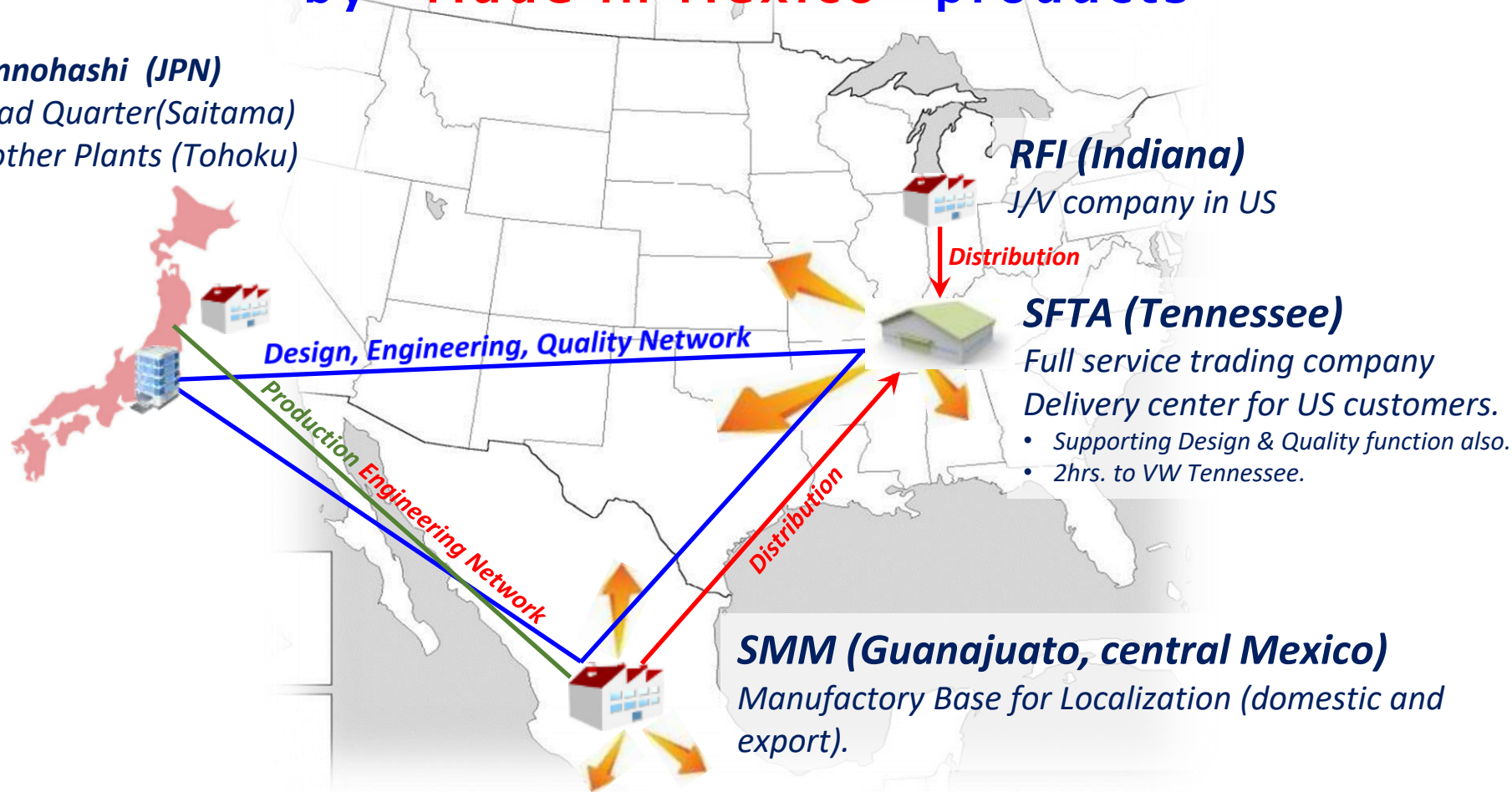

Main Global Customers



Confidential

Company Name	Sannohashi Manufacturing Mexico S.A. de C.V.
Address	Circuito San Roque Sur No.503 Int. A, Parque Industrial Santa Fe II, Silao, GTO., CP 36275 Mexico
Capital	US\$20,900,000 (\$417,659,817 MXN)
Shareholder	Sannohashi Corporation (Japan) Tohoku Sannohashi Corporation (Japan)
Employees	Around 130 Employees (as of April 2024)
General Director	Koji SAITO (Japanese)
Plant Area	Approx. 6,500m ²
Main Products	Sophisticated Engine Bolts / Pins and others (Please refer to Product pages.)
URL	http://www.sannohashi.co.jp/



SMM History

- Oct, 2012** Company Founded
- Jan, 2013** Starts Sales Operations
- Apr, 2013** Plant facility completed
- May, 2014** Mass Production starts
- Aug, 2014** Assessment Audit approved by NISSAN
- Sep, 2014** TIER 1 Business starts
- Dec, 2015** Mass Production for NISSAN starts (Fastener Business)
- Apr, 2017** ISO:9001 Obtained
- Oct, 2022** IATF 16949 Obtained



IATF 16949 Certificate



RA02-0172/2022
IATF:0459171
AENOR certifies that the organization

SANNOHASHI MANUFACTURING MÉXICO S.A. DE C.V.

has a quality management system according to the IATF 16949:2016 Standard

At the following site of production: Circuito San Roque Sur No. 503 Int. A. Parque Industrial Santa Fe Ampliación. 36275 - Silao (GUANAJUATO - México)

For the following activities: Design and manufacture of bolts, nuts and forged pieces

Exclusion: None

Remote location: See Annex

First issued on: 2022-10-07
Validity date: 2025-10-06



Rafael GARCÍA MEIRO
Chief Executive Officer



AENOR INTERNACIONAL, S.A.U.
Génova, 6. 28004 Madrid. España
Tel. 91 432 60 00 - www.aenor.com

Page 1 of 2

Main Customers in Mexico

Supply to various OEMs direct and Tier 1.



RENAULT NISSAN MITSUBISHI



Nissan Trading Corporation Americas



HONDA

Location

Located in Central of Mexico, easy access to various directions



Located in Silao, GTO
Easy access to various directions.

- Aguascalientes; 2 h
- San Luis Potosí; 3 h
- Port of Manzanillo; 6 h
- Airport of Guanajuato; 10 min
- CDMX; 4.5 h
- Puebla; 6 h

Location (Puerto Interior)

SANNOHASHI



- ✓ Neighboring to Int'l Airport Leon (BJX)
- ✓ 30 min. drive from downtown of León
- ✓ Approx. 50 Japanese companies in the same industrial park

Plant Layout

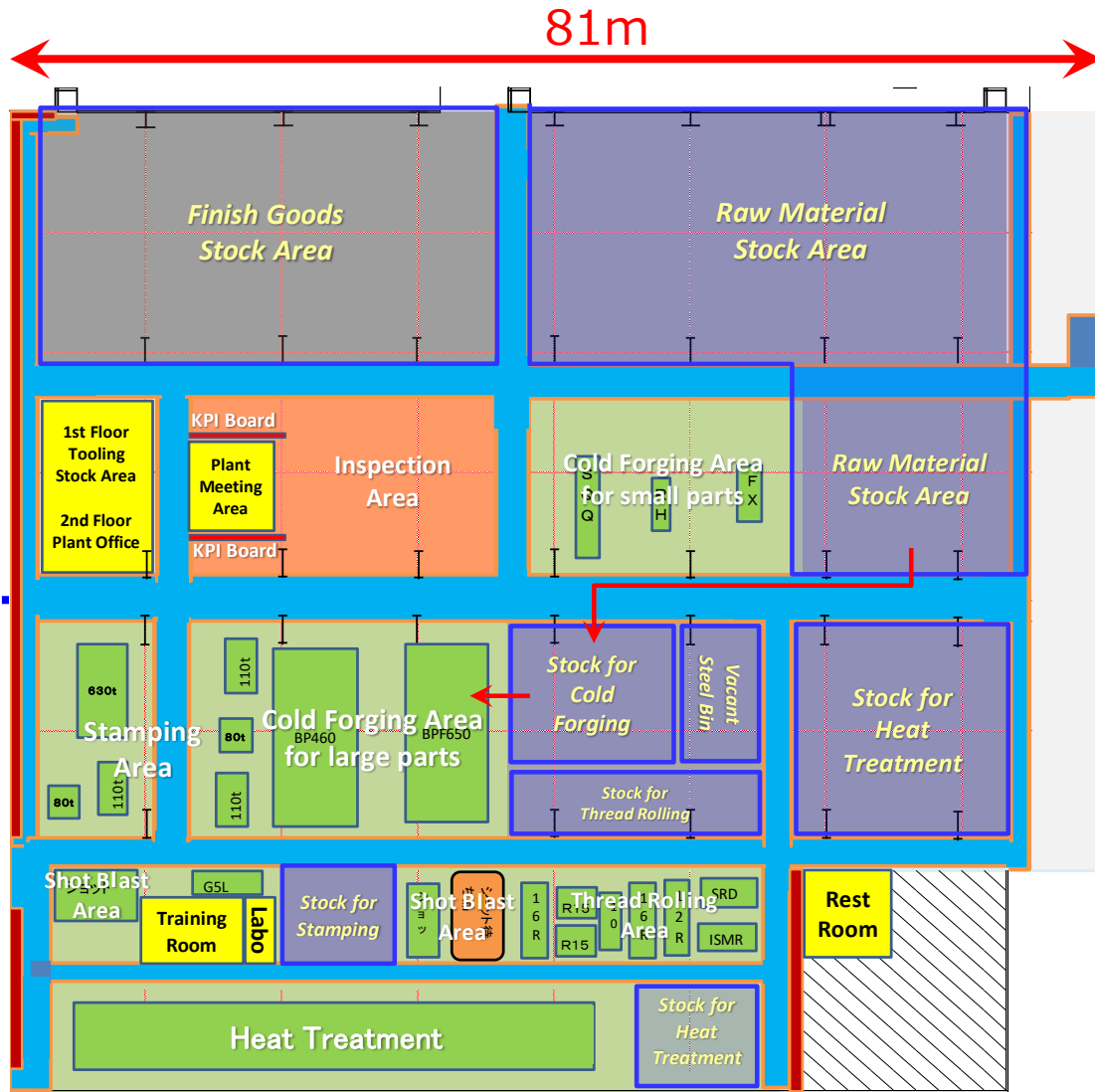





Expanded Area (2019)

Original Area

80m

Total Area
6,400m²

PROCESS	MACHINE	
Cold Forging	5 sets in operation 1 new set (installing)	
Thread Rolling	9 sets	
Press Machines	From 80 ~ 630 T 5 sets	
Heat Treatment	1 Line	

✓ For Steering System



Pinion Gear



Ball stud, Tie Rod, Outer Sockets

✓ For Engine Units

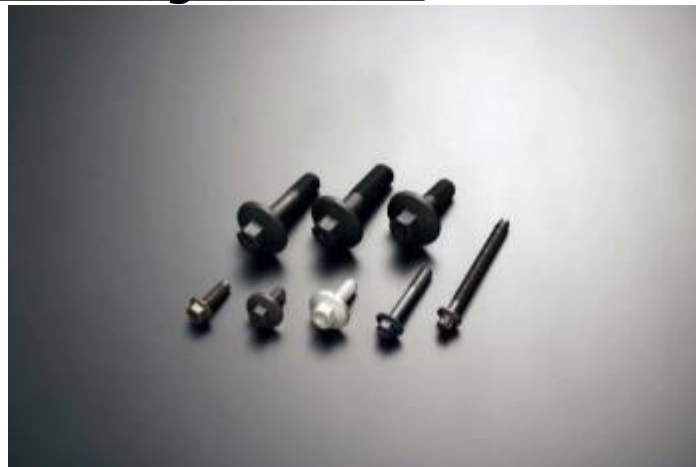

Crank Pulley Bolt, Cam Shaft Bolt, etc.



Cylinder Head Bolt, etc.

✓ For Suspension System



Suspension Slant Axial Pins



Body Mounting Pins



Dog Bone (for fixing Suspension)

✓ For Body System & others



Various Flange Bolts



Flange Bolts with Washer Assembly

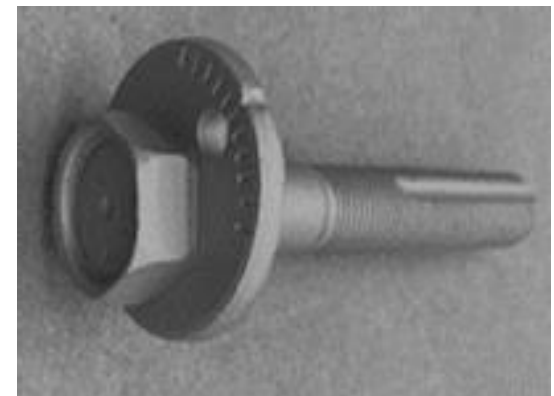

Toe Adj. Bolt

Where Our Products are used

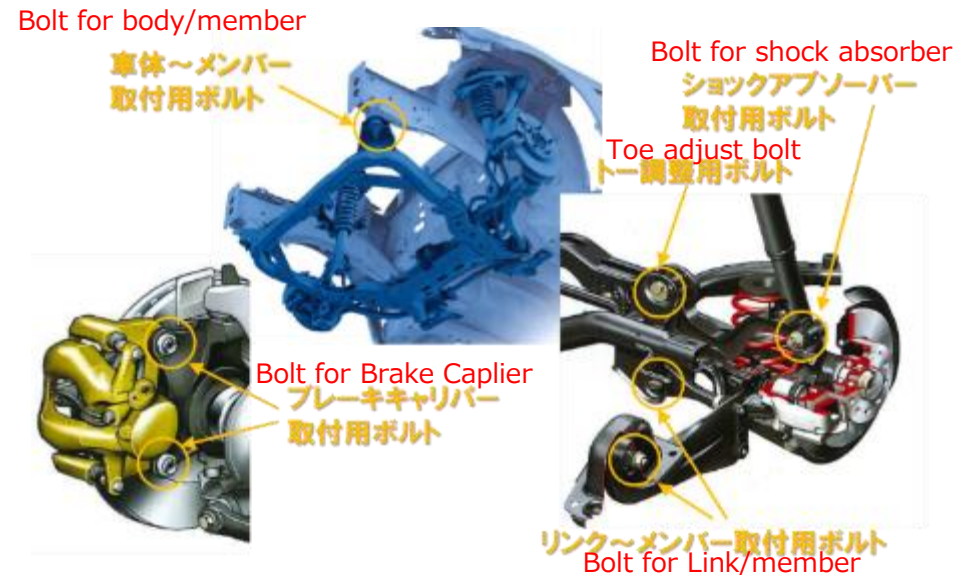
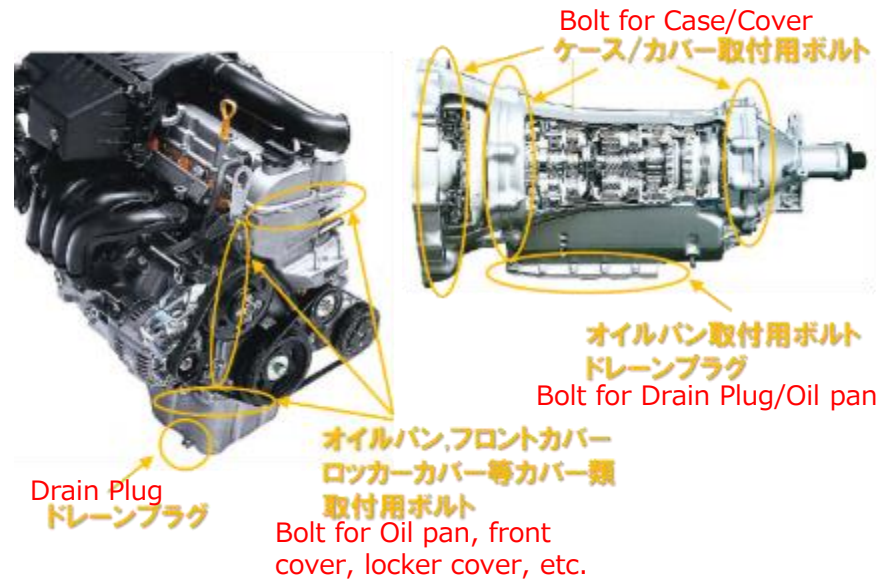
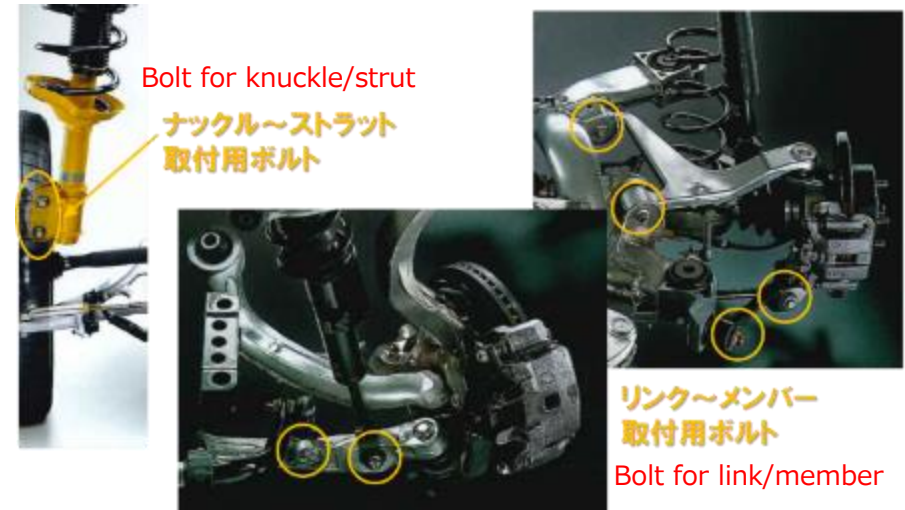
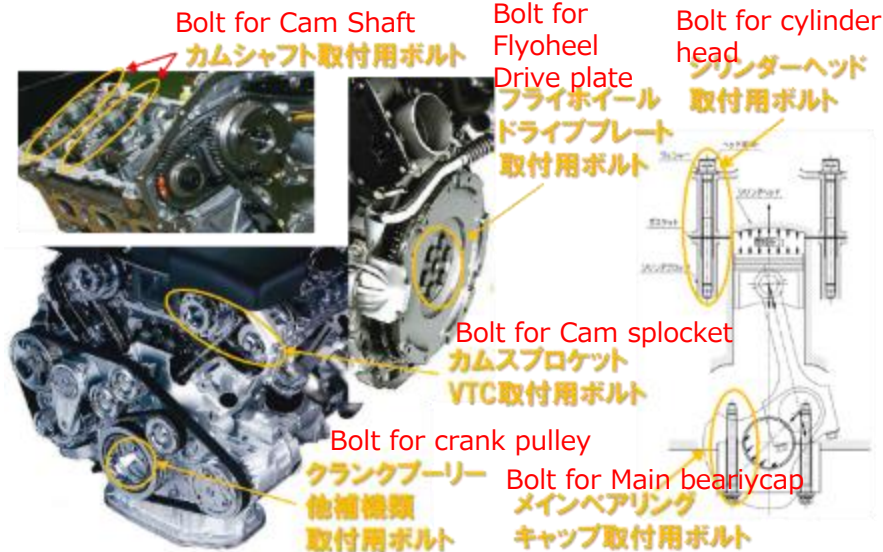

Vehicles using Our Products



Infiniti QX50



Nissan Altima



Nissan Sentra



Nissan Versa



Nissan Kicks



Nissan NAVARA



Ford T6 Ranger



Mazda 3



Honda CIVIC



Honda CRV



Honda Pilot



Mazda CX-30

Material Advantage

Sannohashi is one of the stockholders of drawing company “POSCO - MVWPC”, located in Celaya, Guanajuato.

- Strong relationship with the Material Supplier
- Shorter logistics = less quality risk
- Quick and Flexible deliveries

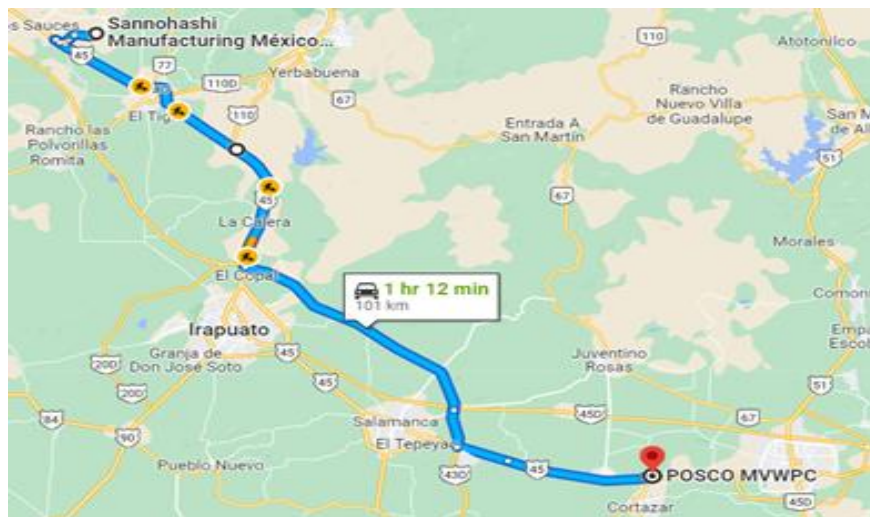

THANK YOU

Contact info :

Tomoyuki Kubota, SMM General Manager of Sales

t.kubota@smmexico.mx

Carlos Sanchez, SMM Sales Manager

sales.manager@smmexico.mx

Hugo, Frausto, SMM, Sales

rep.ventas@smmexico.mx

Contact Address :

Hiroyuki NAKAI, Managing Director, SFTA & Vice President SMM

h.nakai@sannohashi-fta.com

Bailey Penton, SFTA, Sales

b.penton@sannohashi-fta.com